

TECHNICAL MANUAL

**OPERATOR, ORGANIZATIONAL,
DIRECT SUPPORT, GENERAL SUPPORT, AND DEPOT MAINTENANCE MANUAL**

FREQUENCY CONVERTER

MODEL 5255A

This manual contains copyrighted material by permission of
Hewlett-Packard, Palo Alto, California

TM 11-6625-2485-15

TECHNICAL MANUAL
NO. 11-6625-2485-15

HEADQUARTERS
DEPARTMENT OF THE ARMY
WASHINGTON, D.C., 31 MARCH 1972

OPERATOR, ORGANIZATIONAL, DIRECT SUPPORT, GENERAL SUPPORT,
AND DEPOT MAINTENANCE MANUAL
FREQUENCY CONVERTER MODEL 5255A

	Page
CHAPTER A Introduction	1-1
1 General Information	1-3
2 Installation	2-1
3 Operation	3-1
4 Principles of Operation	4-1
5 Maintenance	5-1
6 Circuit Diagrams	6-1
APPENDIX A References	A-1
B Maintenance Allocation	A-2

Figure 1-1. Model 5255A Frequency Converter Plug-In



CHAPTER A

INTRODUCTION

A-1. SCOPE

a. This manual describes the Hewlett-Packard Model 5255A Frequency Converter and covers its installation, operation, and organizational, direct and general support maintenance.

b. Throughout this manual, where appropriate, references are made to other publications which contain information applicable to the operation and maintenance of the Frequency Converter. A complete listing of applicable reference publications is provided in appendix A.

c. The maintenance allocation chart appears in appendix B.

A-2. INDEX OF PUBLICATIONS

a. DA PAM 310-4. Refer to the latest issue of DA PAM 310-4 to determine whether there are new editions, changes, or additional publications pertaining to the equipment.

b. DA PAM 310-7. Refer to DA PAM 310-7 to determine whether there are modification work orders (MWO's) pertaining to the equipment.

This technical manual is an authentication of the manufacturer's commercial literature and does not conform with the format and content specified in AR 310-3, Military Publications. This technical manual does, however, contain available information that is essential to the operation and maintenance of the equipment.

A-3. FORMS AND RECORDS

a. Report of Maintenance and Unsatisfactory Equipment. Use equipment forms and records in accordance with instructions in TM 38-750.

b. Report of Packaging and Handling Deficiencies. Fill out and forward DD Form 6 (Report of Packaging and Handling Deficiencies) as prescribed in AR 700-58 (Army)/NAVSUP PUB 378 (Navy)/AFR 71-4 (Air Force)/and MCO P4030. 29 (Marine Corps).

c. Discrepancy in Shipment Report (DISREP) (SF361). Fill out and forward Discrepancy in Shipment Report (DISREP) (SF361) as prescribed in AR 55-38 (Army)/NAVSUP PUB 459 (Navy)/AFM 75-34 (Air Force)/and MCO P4610. 19 (Marine Corps).

d. Reporting of Equipment Manual Improvements. The reporting of errors, omissions, and recommendations for improving this publication by the individual user is encouraged. Reports should be submitted on DA Form 2028 (Recommended Changes to Publications) and forwarded direct to Commanding General, U.S. Army Electronics Command, Attn: AMSEL-MA-CT. Fort Monmouth, N.J. 07703.

A-4. ADMINISTRATIVE STORAGE

For procedure, forms and records, and inspection required during administrative storage of this equipment, refer to TM 740-90-1.

CHAPTER 1

GENERAL INFORMATION

1-1. DESCRIPTION.

1-2. The Hewlett-Packard Model 5255A Frequency Converter is a plug-in unit which extends the frequency measuring capability of 50 MHz Electronic Counters from 3 to 12.4 GHz (300 Mc to 12400 Me). It can be used for measurements from 2.6 GHz to 12.6 GHz; see Section III. Refer to appropriate counter manual for complete operation instructions.

1-3. The stability and accuracy of the basic counter are retained by multiplying a 10 MHz signal, derived from the 1 MHz internal time base of the counter, to 200 MHz and selecting a harmonic frequency between 2.8 and 12.4 GHz. This known harmonic of 200 MHz is then heterodyned with the INPUT signal. The resulting difference frequency, if between 1 MHz and 212 MHz (bandwidth of amplifier in plug-in) is counted and displayed by the counter. The frequency of the INPUT signal is then indicated by the combination of the MIXING FREQUENCY control (in gigahertz; front panel of plug-in) and the digital display of the counter (in megahertz). Because of a prescaling factor of 4 in the converter, the counter gate times are automatically extended by a factor of 4 for a direct readout.

1-4. The AUX IN jack may be used with 5 mV to 225 mV and 1 to 200 MHz input signals. The signal will be prescaled by 4 and counted by the counter. This extends the direct reading frequency range of the counter to 200 MHz and increases the sensitivity of the counter to 5 mV for 1 to 200 MHz inputs.

1-5. The AUX OUT jack output comes from the video amplifier output and is the amplified difference frequency between the input signal and the selected mixing frequency.

1-6. A front panel meter, by monitoring the difference frequency output of the plug-in to the counter,

aids in selecting the desired MIXING FREQUENCY and also in determining if INPUT signal amplitude is adequate for accurate frequency measurement.

1-7. SPECIFICATIONS.

1-8. Table 1-1 contains all technical specifications for the Model 5255A when operated in HP Electronic Counters.

1-9. INSTRUMENT IDENTIFICATION.

1-10. Each Model 5255A is identified by a two-section, eight digit (000-00000) serial number on the rear of the plug-in. The five-digit number is an identification number unique to each instrument, and the three digit number is a serial prefix number used to document changes.

1-11. All instruments with the same serial prefix are the same. The group of instruments to which this manual applies directly is identified on the title page. For older instruments (lower serial numbers), make manual changes listed in appendix A. For newer instruments, having serial numbers higher than those listed on the title page, a Manual Change sheet is included, describing the required changes. The manual for an instrument having special electrical modification will include an insert sheet describing that modification. If a change sheet or special information sheet is missing, the information can be supplied by any Hewlett-Packard sales and service office listed at the back of this manual.

1-12. COOLING.

1-13. The Model 5255A is cooled by the ventilation system of the counter in which it is installed. See counter service manual for cooling system maintenance instructions.

Table 1-1. Specifications *

RANGE: As a converter for HP Electronic Counters, 3 to 12.4 GHz using mixing frequencies of 2.8 to 12.4 GHz in 200 MHz steps. As a prescaler, 1 MHz to 200 MHz.

ACCURACY: Retains counter accuracy.

INPUT SENSITIVITY: 100 mV rms (-7 dBm) as a converter. 5 mV rms as a prescaler.

INPUT IMPEDANCE: 50 ohms nominal.

MAXIMUM INPUT: +10 dBm; 0 dBm on AUX IN.

LEVEL INDICATOR: Meter aids frequency selection; indicates usable signal level.

AUXILIARY OUTPUT: 1 MHz to 200 MHz difference signal from video amplifier.

REGISTRATION: Counter display in MHz is added to converter dial reading.

INSTALLATION: Plugs in to front panel plug-in compartment of HP 5245L or 5246L Electronic Counters.

INPUT CONNECTOR: Precision Type N female. GPC-7 connector optional.

WEIGHT: Net, 8-1/4 lbs. (3, 8 kg).
Shipping, 12 lbs. (5, 5 kg).

* When used with HP 50 MHz Electronic Counters; Model 5245L prefixed 402 and above or Model 5246L.

CHAPTER 2

INSTALLATION

2-1. INTRODUCTION.

2-2. This section contains information on unpacking, inspection, repacking, storage, and installation. "

2-3. UNPACKING AND INSPECTION.

2-4. If the shipping carton is damaged, ask that the carrier's agent be present when the instrument is unpacked. Inspect the instrument for damage (scratches, dents, broken knobs, etc). If the instrument is damaged or fails to meet specification (Performance Check, Table 5-5), notify the carrier and the nearest Hewlett-Packard sales and service office immediately (sales and service offices are listed at the back of this manual). Retain the shipping carton and the padding material for the carrier's inspection. The sales and service office will arrange for the repair or replacement of your instrument without waiting for the claim against the carrier to be settled.

2-5. STORAGE AND SHIPMENT.

2-6. PACKAGING. To protect your instrument during shipment or storage, use the best packaging methods available. Your Hewlett-Packard sales and service office can provide materials similar to those used for original factory packaging. Contract packaging companies can provide dependable custom packaging on short notice.

a. If possible, use the original container designed for the instrument. Otherwise, use a strong carton (350 lb/sq inch bursting strength) or wooden box to house the instrument.

b. Wrap the instrument in heavy paper or plastic before placing it in the shipping container.

c. Use plenty of packing material around all sides of the instrument and protect the front panel with cardboard strips.

d. Seal the package with strong tape or metal bands. Mark with "Delicate Instrument".

e. Refer to the address list at the rear of this manual and check with your Hewlett-Packard sales

and service office for shipping instructions. All correspondence should refer to an instrument by Model number and the full eight-digit serial number.

2-7. ENVIRONMENT. Conditions during storage and shipment should normally be limited as follows:

a. Maximum temperature 167°F (75°C).

b. Minimum temperature -40° F (-40°C).

CAUTION

TURN COUNTER POWER OFF BEFORE INSTALLING OR REMOVING FREQUENCY CONVERTER. "

2-8. INSTALLATION.

2-9. The Model 5255A plugs into the rectangular compartment at the right-hand side of the front panel of the Electronic Counter. To install unit in counter, first check that retaining latch is turned fully counterclockwise, then push unit firmly into compartment until front panel of plug-in is flush with front panel of counter. Then turn retaining latch clockwise until it is tight.

2-10. To remove unit from counter, turn retaining latch counterclockwise to its stop. Then grasp mixing frequency selector and firmly pull unit from counter. If any difficulty is encountered with installation or removal, check that retaining latch is fully counterclockwise.

2-11. POWER REQUIREMENTS.

2-12. All electrical power required to operate the Model 5255A is supplied by the counter in which the unit is installed.

2-13. ELECTRICAL CONNECTIONS.

2-14. The INPUT, AUX IN, and AUX OUT connectors on front panel of plug-in (see Figure 3-1) are the only external electrical connections to the unit. All other connections are made through the 50-pin connector at the rear of plug-in when installed in counter.

Figure 3-1. Model 5255A Operating Procedure

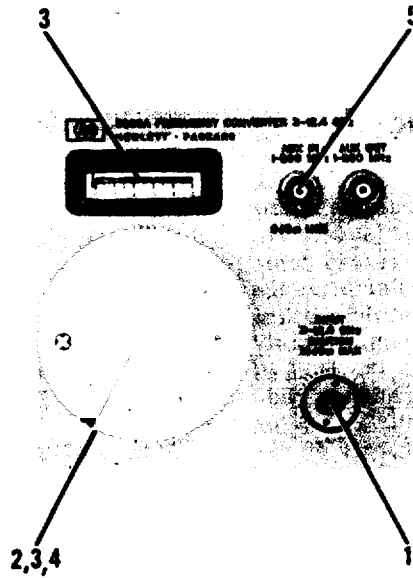

FREQUENCY MEASUREMENTS

See appropriate counter operating manual for complete operating instructions.

1. Connect input signal to INPUT of converter.
2. Set Mixing Frequency control to read slightly less than 2.8 GHz.
3. Slowly turn Mixing Frequency control counter-clockwise to obtain the first response, and tune for a maximum reading in the green portion of the Level Indicator Meter scale.

4. Add counter display (in kHz) to Mixing Frequency control reading (in GHz) for frequency of INPUT signal.

USE OF AUX IN

5. To use prescaler portion of plug-in connect the 1 to 200 MHz input signal to the AUX IN jack (0 dBm max).
6. The counter will display frequency of input signal. (During this measurement the main input to the converter should be disconnected, or, if a microwave signal is present at the main input, the converter should be detuned so that there is no counter reading from that source.)

CHAPTER 3

OPERATION

3-1. DESCRIPTION.

3-2. The Model 5255A Frequency Converter increases the range of the 50 MHz Electronic Counter to 3 through 12.4 GHz (3000 to 12,400 MHz). As a general rule to measure frequency, always start with the Mixing Frequency Control below 3 GHz and tune upward in frequency to obtain first response and tune for a maximum reading in the green portion of the meter scale. This procedure will be valid whether there are responses in 1, 2, or 3 consecutive harmonic reference frequencies; see Table 3-2. If the input signal level to the converter is high, the second, third, and other harmonics of this signal may be generated. Therefore, tuning Mixing Frequency Control from the low end upward will enable the input fundamental frequency to be detected before its harmonics. In the 5255A harmonics of the reference-frequency signals are held to such a low level that regardless of input signal level, their mixing effects are not observable, avoiding possible ambiguity. Figure 3-1 provides a step-by-step procedure to be used for measurement of frequencies from 3 to 12.4 GHz (3000 to 12,400 MHz). The only exception is if the first response occurs at 2.8 GHz or 3.0 GHz. To avoid possible ambiguity in these cases, start from above 3.4 GHz and tune downward in frequency for the first response and subtract the counter reading from the dial frequency for the frequency of the input signal.

3-3. CONTROLS AND INPUTS.

3-4. GENERAL. The function of the front panel tuning control, input connector, meter, AUX input, and AUX output connectors are described in Paragraphs 3-5 through 3-9.

3-5. INPUT CONNECTOR. Signal input, 50 ohms input impedance, 100 mV (-7 dBm) to 707 mV (+10 dBm) into precision type "N" female connector (APC-7 or "N" type male connectors are optional).

3-6. MIXING FREQUENCY SELECTOR. Calibrated from 2.8 GHz to 12.4 GHz (2800 MHz to 12,400 MHz), this control tunes the internal cavity to select a harmonic of 200 MHz to be mixed with the INPUT signal.

3-7. LEVEL INDICATOR METER. The meter circuit continuously monitors the level of the difference frequency output of the converter to the counter. When meter reads in the green portion of its scale,

INPUT signal amplitude is adequate for accurate frequency measurement.

3-8. AUX IN. Signals connected to this input of 5 mV (-33 dBm) up to 224 mV (0 dBm) and 1 to 200 MHz at the AUX IN jack will be counted and displayed directly.

3-9. AUX OUT. The output from the AUX OUT jack is the 1 to 200 MHz difference signal from the video amplifier.

Note

If any difficulty occurs while making measurements, check all cables and connectors for resonant points.

3-10. MAXIMUM INPUT VOLTAGE.

3-11. Damage to the converter may result if an AC signal greater than .707 V rms (+10 dBm) or a DC voltage greater than 5 V is applied to converter INPUT connector.

3-12. FREQUENCY MEASUREMENT WITH AMPLITUDE LESS THAN 100 MV RMS.

3-13. The front panel level indicator meter indicates in the green portion of its scale only when converter is properly tuned and amplitude of INPUT signal is adequate for accurate frequency measurement. (Because of conservative specifications of the converter this will usually occur with an input signal less than 100 mv.)

3-14. DOUBLE CHECKING FREQUENCY MEASUREMENT RESULTS.

3-15. Because of the heterodyne action of the converter, frequency measurement results obtained at any one setting of the Mixing Frequency Control may be checked at other settings. In most cases these will be consecutive responses: tune in the first response and add the counter display to dial frequency reading; then tune up in frequency to the second response and subtract the counter display from the dial frequency reading (see Table 3-1). In some cases there will be three consecutive responses (see Table 3-2); in these cases the third response will be the one in which you subtract the counter display from the dial frequency reading.

Table 3-1. Typical Double-Check Frequency Measurement

Input Frequency	Counter Reading	Mixing Frequency	Meter Indication	Response
8.1234567 GHz	.1234567 GHz	8.0 GHz	Peak	First Response: 8.000000 GHz + .1234567 GHz <u>8.1234567 GHz</u>
	.0765433	8.2 GHz	Peak	Second Response: 8.200000 GHz - .0765433 GHz <u>8.1234567 GHz</u>

Table 3-2. Typical Frequency Measurements

Input Frequency	Display	Meter	Mixing	Response
EXAMPLE OF ONE RESPONSE				
2600 MHz	000000.00 MHz	Red	3.0 GHz	No response; frequency difference greater than passband of video amplifier
	000200.00 MHz	Green	2.8 GHz	First Response: * 2800 MHz <u>-200 MHz</u> 2600 MHz
12,600 MHz	000000.00 MHz	Red	12.2 GHz	No response; frequency difference greater than passband of video amplifier
	000200.00 MHz	Green	12.4 GHz	First Response: 12,400 MHz <u>+ 200 MHz</u> 12,600 MHz
EXAMPLE OF TWO RESPONSES				
10,050 MHz	000050.00 MHz	Green	10.0 GHz	First Response: 10,000 MHz <u>+ 50 MHz</u> 10,050 MHz
	000150.00 MHz	Green	10.2 GHz	Second Response: 10,200 MHz <u>- 150 MHz</u> 10,050 MHz
4000 MHz	000200.00 MHz	Green	3.8 GHz	First Response: 3800 MHz <u>+200 MHz</u> 4000 MHz
	000000.00 MHz	Red	4.0 GHz	No response; difference frequency less than passband of video amplifier
	000200.00 MHz	Green	4.2 GHz	Second Response: 4200 MHz <u>-200 MHz</u> 4000 MHz
EXAMPLE OF THREE RESPONSES				
11,005 MHz	000205.00 MHz	Green	10.8 GHz	First Response: 10,800 MHz <u>+ 205 MHz</u> 11,005 MHz
	000005.00 MHz	Green	11.0 GHz	Second Response: 11,000 MHz <u>+ 5 MHz</u> 11,005 MHz
	000195.00 MHz	Green	11.2 GHz	Third Response: 11,200 MHz <u>- 195 MHz</u> 11,005 MHz
*When response present at 2.8 or 3.0 GHz, tune from above and subtract first reading, (See Paragraph 3-2).				

CHAPTER 4

PRINCIPLES OF OPERATION

4-1. GENERAL.

4-2. The Model 5255A is a heterodyne frequency converter designed to extend the range of frequency measurement of the Electronic Counters to 2.8 GHz through 12.4 GHz (2800 MHz through 12,400 MHz).

4-3. The Converter contains ten basic functional sections: phase detector, 10 MHz oscillator, 50 MHz multiplier -amplifier, 200 MHz multiplier-amplifier, harmonic generator, mixer-cavity, video amplifier, prescaler, control circuit, and gate time extender. (See Figure 4-1, and for circuit details refer to the schematic diagrams Figures 6-2 through 6-8.)

4-4. In normal operation the harmonic generator produces all of the harmonics of 200 MHz between 2.8 MHz and 12.4 MHz. The harmonic selector cavity is tuned to select one of these harmonics to be supplied to the mixer. The mixer output is the difference frequency produced by mixing of the input frequency and the frequency supplied by the harmonic selector cavity. This difference frequency is amplified by the video amplifier and supplied to the counter input circuit. The output of the video amplifier is monitored by a control circuit which indicates when difference frequency output amplitude is greater than the minimum signal required by the counter input circuit.

ence frequency output amplitude is greater than the minimum signal required by the counter input circuit.

Note

In the following discussion complete reference designations are used to identify components. This is to prevent confusion between reference designations of components located on the chassis and components located on an assembly. For example, "R1" would refer to a component located on the chassis, while "A1R1" would refer to a component located on the phase detector assembly A1 (see Table 5-1 for assembly designations).

4-5. PHASE DETECTOR A1.

4-6. The Phase Detector holds the 10 MHz generated by the voltage tuned oscillator on assembly A2 in phase lock with the 10 MHz signal from the counter. This creates a phase locked loop which acts as a narrow band filter at 10 MHz. The two 10 MHz signals are added by A1Q2 and A1Q3 then detected by A1CR4 and A1CR5. The detected signal is the phase control signal and passes through an emitter follower, A1Q5, before being sent to assembly A2.

4-7. If the reference 10 MHz should not be present (if for example the counter should be switched to EXT

STD with no external standard present) a "no lock" signal is generated. Limiter A1Q1 turns off when there is no 10 MHz signal at its base. That in turn switches on the "on" gate A1Q7 and A1Q8 generating a "no lock" signal. A no lock signal will also be generated if the 10 MHz from the counter pulls out of phase lock with the 10 MHz generated by the oscillator on assembly A2. Should this occur the phase control signal would be a beat note. This beat note is detected by A1CR6 and A1CR7. The detected signal passes through an emitter follower and switches on the "on" gate to produce the no lock signal. The no lock signal is sent to the control board where it is used to inhibit counting.

4-8. The test signal at pin S of A1 is available an active AUX B output of the counter. If the phase detector is operating normally there will be 0 volts dc at the test point. "No Lock" condition will be shown by +13 volts. The test signal is AC coupled to the phase control signal so that if a beat note is present it can also be seen at AUX B superimposed upon the out-of-lock dc signal. (Note: Except for the special case of a disconnected external reference to the counter, in normal operation a "no lock" signal will not occur.) Such a signal indicates failure of the counter reference signal or failure within the converter. The "no lock" signal prevents erroneous readings in the event of such a failure.

4-9. 10 MHz OSCILLATOR A2.

4-10. The oscillator assembly consists of an active low pass filter and a voltage tuneable crystal oscillator. The oscillator is held at exactly the same frequency as the 10 MHz counter reference signal by the phase control signal from A1. This signal first passes through the low pass filter then is applied to varactors A2CR1 and A2CR2, which tunes the oscillator to hold phase lock. Output from the oscillator goes to both the phase detector, for comparison with the 10 MHz reference, and to the 50 MHz multiplier-amplifier A3.

4-11.50 MHz MULTIPLIER AMPLIFIER A3.

4-12. The 10 MHz output from A2 is multiplied to 50 MHz in the first stage A3Q1. The rest of A3 is a narrow -band synchronously tuned 50 MHz amplifier. The last stage of A3 is a partial limiter as well.

4-13. 200 MHz MULTIPLIER AMPLIFIER R4

4-14. The 50 MHz signal from A3 is doubled in the first stage of A4 to 100 MHz then doubled again in A4Q2 to 200 MHz. The remaining stages furnish narrow-band (synchronously tuned) amplification at 200 MHz. The output level from the last stage is controlled by R12.

Figure 4-1. Functional Block Diagram

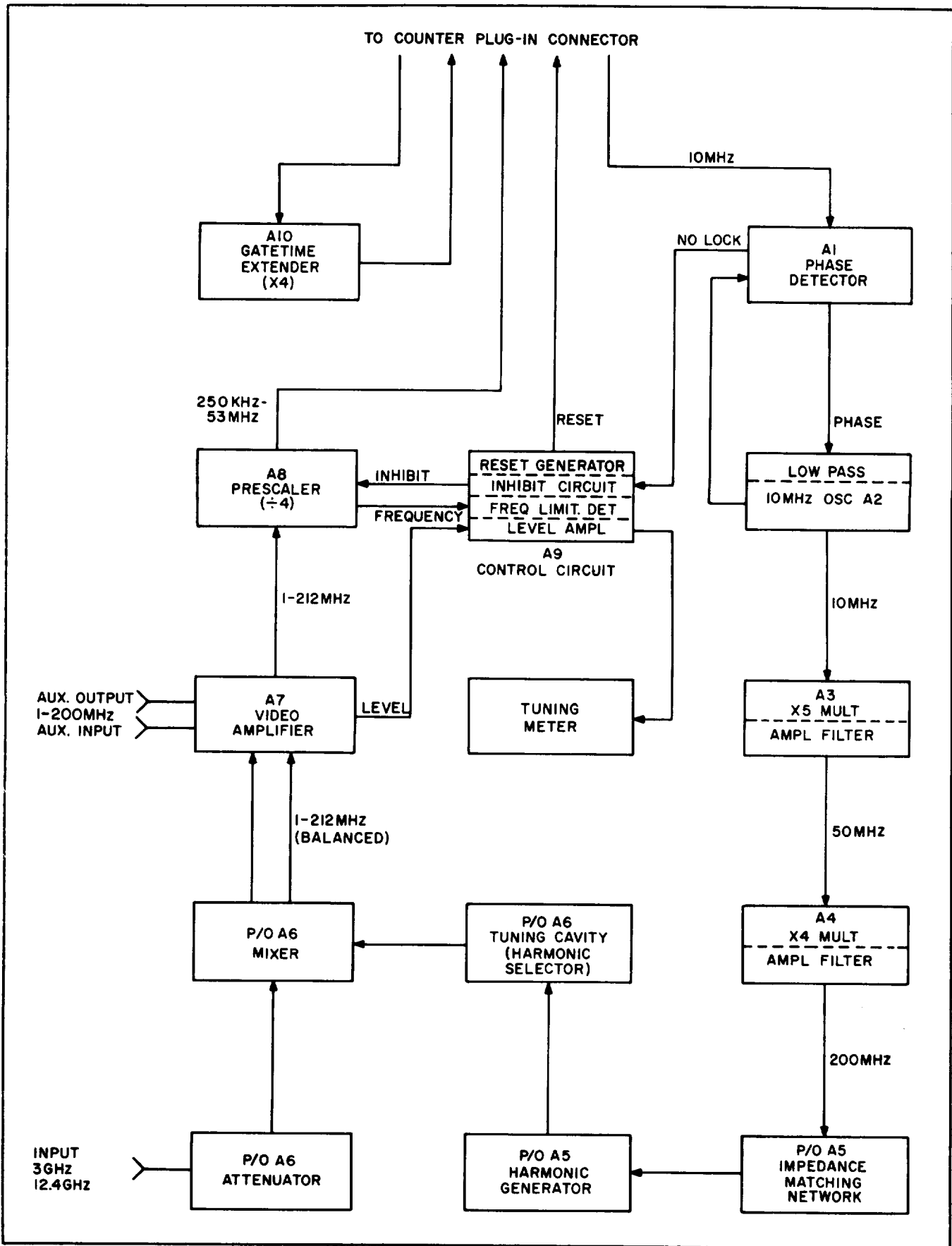

4-15. HARMONIC GENERATOR A5.

4-16. The 200 MHz signal from the multiplier amplifier A4 passes through the matching network to drive the step recovery diode A5CR1, A5CR1 generates harmonic energy which it couples into the resonate tuning cavity. The dc voltage generated by A5CR1 is available at the test point on A5 (see Figure 6-5).

4-17. MIXER-CAVITY A6.

4-18. The input signal from J1 passes through the attenuator to the mixing diodes. The signal from the tuning cavity is also coupled to the mixing diodes. The two signals are mixed and the difference frequency is the signal to the video amplifier A7.

4-19. VIDEO AMPLIFIER A7.

4-20. The video amplifier assembly is a wideband feedback stagger -tuned amplifier with a voltage gain of 50 dB into 50 ohms.

4-21. The two signals from the balanced mixer in A6 is applied to the base of A7Q2 through A7T1. A7Q2, A7Q4, A7Q6, A7Q8, and A7Q10 amplify the input signal. A7Q1 is used to bias A7Q2 and A7Q3, A7Q5, A7Q7, and A7Q9 perform the same function in relation to the signal path transistors A7Q4, A7Q6, A7Q8, and A7Q10 respectively. The output from A7Q10 drives the prescaler A8 and is applied to the base of A7Q11 and A7Q12. A7Q12 is another amplifier whose output is detected by A7Q13 and A7Q14. The detector provides a dc current which is proportional to the magnitude of the input signal. Diodes A7CR5 and A7CR6 provide temperature stability to the detector circuit. The voltage at the collector of A7Q13 is the amplitude level signal which drives the tuning meter section of the control circuit A9. The voltage level at the collector of A7Q14 controls the operation of the AGC circuit which prevents distortion from high level input signals. When the amplified input signal is sufficiently large and the collector voltage of A7Q14 decreases to less than 3 V, both A7Q15 and A7Q16 are turned on. When A7Q16 draws current, A7CR1, A7CR2, and A7CR4 are all forward biased. A7CR1 and A7CR2 shunt part of the signal coming from AUX IN and A7CR4 provides shunting in the 3rd stage of amplification.

4-22. The signal from AUX IN jack J2 is resistively isolated from the main input. It has a 50 ohm input impedance and a sensitivity 12 dB lower than the main input. AUX OUT is isolated from the main output by A7R48 and A7Q11. The voltage gain between AUX OUT and AUX IN is 25 dB into 50 ohms.

4-23. PRESCALER ASSEMBLY A8.

4-24. The prescaler input is a 1 to 212 MHz signal from the video amplifier A7. This signal is amplified by input amplifier A8Q2. The output of A8Q2 fires

tunnel diode trigger A8CR1. The square wave from the trigger is amplified by A8Q1 and differentiated by A8R3, A8L3. The differentiated signal is amplified and the positive pulses clipped by driver amplifier A8Q4. The output from A8Q4 drives binary A. The output of binary A goes through buffer amplifier A8Q9. The output of A8Q9 is differentiated by A8R21, A8L6, and amplified and clipped by A8Q10. The output of A8Q10 drives binary B. Binary B outputs go through buffer amplifiers A8Q14 and A8Q15 to output amplifiers A8Q16 and A8Q17. A8Q16 output goes to the AUX A jack on the rear of the counter and A8Q17 output is the signal input to the counter.

4-25. CONTROL CIRCUIT A9.

4-26. The Control Circuit Assembly performs the following functions:

a. It drives the tuning meter with a current proportional to the amplitude level signal from the video amplifier. The level signal from the video amplifier passes through emitter follower A9Q6 before being sent to the meter.

b. It inhibits the prescaler if a no lock signal from the phase detector is present or if the input level signal is smaller than that required to move the tuning needle above approximately 3 on the tuning meter scale. A "no lock" signal from the phase detector saturates A9Q7 which inhibits the prescaler. A9Q8 is saturated and also inhibits the prescaler if the (level signal) voltage on the base of A9Q9 is lower than the reference voltage on the base of A9Q10.

c. The control board generates a pulse to reset the counter when the level signal moves the tuning meter up or down past 3 on the tuning meter. A9Q11 is held off by A9CR4 or A9CR5 except when A9Q9 and A9Q10 are both conducting, that is when the amplitude level passes through the inhibit threshold. When A9Q11 conducts it turns on A9Q12. The signal from A9Q12 is differentiated by A9R26 and A9C9 and the pulse thus generated is amplified by A9Q13 to drive the reset line in the counter.

d. The control board clamps the input level signal so that the tuning meter goes to zero if the signal into the "frequency" input from the prescaler is greater than approximately 212 MHz. The "frequency" signal from the prescaler is sent through a high pass filter (A9C1 and A9L1) and a low pass filter (A9C4 and A9L2) and is detected by A9CR1 and A9CR2. Below 212 MHz A9CR2 will detect a larger voltage than A9CR1 and A9Q2 will conduct more than A9Q1. Above 212 MHz A9CR1 will detect a larger signal than A9CR2, and A9Q1 will conduct more than A9Q2. A9Q3 and A9Q4 amplify the difference further and A9Q3 also drives transistor A9Q5 to saturation for "frequency" inputs above 212 MHz. When A9Q5 saturates the meter reading drops to zero. A dc bias adjusted by A9R4 holds A9Q5 out of saturation when there is no "frequency" input signal.

4-27. GATE TIME EXTENDER A10.

4-28. The gate time extender assembly delays the gate trigger signal to the counter gate control by delaying the stop signal to the main counter gate. This is done by multiplying the period of the gate triggering signal from the counter by a factor of 4. The result is a direct readout of the measured frequency.

4-29. The reset pulse from the counter sets the bimarities so A10Q5 and A10Q7 are conducting. The first pulse turns off A10Q5 and turns on A10Q4. The output of A10Q4 turns off A10Q7 and turns on A10Q6. The

output of A10Q6 triggers the gate flip-flop A10Q9, A10Q10. The output of the gate flip-flop is amplified by the start amplifier A10Q8 and opens the main gate of the counter. The second pulse turns off A10Q4 and turns on A10Q5. The third pulse turns A10Q5 off and A10Q4 on. The output of A10Q4 turns A10Q6 off and A10Q7 on. The fourth pulse turns A10Q4 off and A10Q5 on. The fifth pulse turns A10Q5 off and A10Q4 on. The output of A10Q4 turns A10Q7 off and A10Q6 on. The output of A10Q6 triggers the gate flip-flop. The output of the gate flip-flop is amplified by the stop amplifier A10Q12 and closes the main gate of the counter. Five pulses have been counted to measure four periods of the gate triggering signal.

CHAPTER 5

MAINTENANCE

5-1. SCOPE OF MAINTENANCE

a. The maintenance duties assigned to the operator of the Model 5255A are listed below together with a reference to the paragraphs covering the specific maintenance functions. The duties assigned do not require tools or test equipment other than those issued with the equipment.

- (1) Operator's daily preventive maintenance checks and services (para 5-4).
- (2) Operator's weekly preventive maintenance checks and services (para 5-5).
- (3) Cleaning (para 5-7).

b. The maintenance duties assigned to the organizational maintenance repairmen of the equipment are listed below, together with a reference to the paragraphs covering the specific functions. The duties assigned do not require tools or test equipment other than those issued with the equipment.

- (1) Organizational monthly preventive maintenance checks and services (para 5-6).
- (2) Rustproofing and painting (para 5-8).

5-2. PREVENTIVE MAINTENANCE

Preventive maintenance is the systematic care, servicing, and inspection of equipment to prevent the occurrence of trouble, reduce downtime, and assure that the equipment is serviceable.

a. Systematic Care. The procedures given in paragraphs 5-4 through 5-7 cover routine systematic care and cleaning essential to proper upkeep and operation of the

equipment.

b. Preventive Maintenance Checks and Services. The preventive maintenance checks and services charts (para 5-4 and 5-5) outline functions to be performed at specific intervals. These checks and services are designed to maintain Army equipment in a combat-serviceable condition; that is, in good general (physical) condition and in good operating condition. To assist operators in maintaining combat serviceability, the charts indicate what to check, how to check, and the normal conditions; the References column lists the paragraphs that contain detailed repair or replacement procedures. If the defect cannot be remedied by the operator, a higher category of maintenance or repair is required. Records and reports of these checks and services must be made in accordance with instruction given in TM 38-750.

5-3. PREVENTIVE MAINTENANCE CHECKS AND SERVICES PERIODS

Preventive maintenance checks and services of the Model 5255A are required daily, weekly, and monthly.

a. Paragraph 5-4 specifies the checks and services that must be accomplished daily, or under the special conditions listed below:

- (1) Before the equipment is taken on a mission.
- (2) When the equipment is initially installed.
- (3) When the equipment is reinstalled after removal for any reason.
- (4) At least once a week, if the equipment

5-5. OPERATOR'S WEEKLY PREVENTIVE MAINTENANCE CHECKS AND SERVICES.

Sequence No.	Item to be inspected	Procedure	References
1	Cables	Inspect external cables for cuts, cracked, or gouged jackets, fraying, or kinks.	
2	Hardware	Inspect all exterior hardware for looseness and damage. The Model 5255A cover, carrying handle, hinges, and all bolts and screws must be tight and not damaged.	
3	Preservation	Inspect equipment to determine that it is free of bare spots, rust, and corrosion. If these conditions exist, refer to a higher category maintenance for repair.	Para 5-7 and 5-8

5-4. OPERATOR'S DAILY PREVENTIVE MAINTENANCE CHECKS AND SERVICES.

Sequence No.	Item to be Inspected	Procedure	References
1	Model 5255A the frequency converter	Check equipment for completeness and general condition.	Appx B
2	Exterior surfaces	Clean exterior surfaces of equipment.	Para 5-7
3	External receptacles	Inspect external receptacles for breakage and for firm seating.	
4	Meter glass	Inspect front panel glass window for damaged housing, broken glass, physical damage, dust, or moisture.	
5	Knobs, controls, and switches	During operation (item 6), check knobs, controls, and switches for proper mechanical action. Action must be positive, without backlash, binding, or scraping.	
6	Operation	During operation, be alert for any abnormal indications.	

is maintained in standby condition.

b. Paragraphs 5-5 and 5-6 specify additional checks and services that must be performed weekly and monthly. Perform the maintenance functions indicated in the monthly preventive maintenance checks and services chart (para 5-6) once each month. A month is defined as approximately 30 calendar days of 8-hour-per-day operation. If the equipment is operated 16 hours a day, the monthly preventive

maintenance checks and services should be performed at 15-day intervals. Adjustment of the maintenance interval must be made to compensate for any unusual operating conditions. Equipment maintained in a standby (ready for immediate operation) condition must have monthly preventive maintenance checks and services. Equipment in limited storage (requires service before operation) does not require monthly preventive maintenance.

5-6. ORGANIZATIONAL MONTHLY PREVENTIVE MAINTENANCE CHECKS AND SERVICES.

Sequence No.	Item to be inspected	Procedure	References
1	Publications	Check to see that publications are complete, serviceable, and current.	DA Pam 310-4
2	Modification work orders	Check to see that all URGENT MWO's have been applied and that all NORMAL MWO's have been scheduled.	DA Pam 310-7
3	Completeness	Check equipment for completeness and general condition.	Appx B
4	Cleanliness	Clean exterior surfaces of equipment	Para 5-7
5	Preservation	Inspect equipment to determine that it is free of bare spots, rust, and corrosion.	Para 5-7 and 5-8
6	External receptacles	Inspect external receptacles for breakage and for firm seating.	
7	Meter glass	Inspect front panel glass window for damaged housing, broken glass, physical damage, dust, or moisture.	
8	Cables	Inspect external cables for cuts, cracked, or gouged jackets, fraying or kinks.	
9	Hardware	Inspect all exterior hardware for looseness and damage. The Model 5255A cover and all bolts and screws must be tight and not damaged.	
10	Operation	During operation, be alert for any abnormal indications.	

5-7. CLEANING

Inspect the exterior of the Model 5255A. The exterior surface must be free of dust, dirt grease, and fungus.

a. Remove dust and loose dirt with a clean, soft cloth.

WARNING

Prolonged breathing of cleaning compound is dangerous; provide adequate ventilation. Cleaning compound is flammable; do not use near a flame. Avoid contact with the skin; wash off any that spills on the hands.

b. Remove grease, fungus, and ground-to dirt from the cases; use a cloth dampened (not wet) with Cleaning Compound (Federal Stock No. 7930-395-9542).

c. Remove dust or dirt from input connector with a brush.

CAUTION

Do not press on the meter face (glass) when cleaning; the meter may become damaged.

d. Clean the front panel, meter, and control knobs; use a soft, clean cloth. If necessary, dampen the cloth with water; mild soap may be used for more effective cleaning.

5-8. RUSTPROOFING AND PAINTING

a. Rustproofing. When the finish on the Model 5255A has become badly scarred or damaged, rust and corrosion can be prevented by touching up the bare surfaces. Use No. 000 sandpaper to clean the surface down to the bare metal. Obtain a bright, smooth finish.

b. Painting. Remove rust and corrosion from metal surfaces by lightly sanding them with fine sandpaper. Brush two thin coats of paint on the bare metal to protect it from further corrosion. Refer to the applicable cleaning and refinishing practices specified in TB SIG 364.

5-9. LUBRICATION INSTRUCTIONS

a. Gasoline should not be used as a cleaning fluid for any purpose. When the equipment is overhauled or repairs are made, clean the parts with cleaning compound.

b. Do not use excessive amounts of Lubricating Oil, Instrument (OAI) (FSN 9150-664-6518) and do not allow connections to become greasy.

c. Be sure that lubricants and points to be lubricated are free from sand, grit, or dirt. Use cleaning compound to clean all parts. Before lubrication, clean all surfaces to be lubricated; use a lint-free cloth dampened with cleaning compound. Keep cleaning off surrounding parts.

d. Lubrication intervals designated are for daily 8-hour periods of operation. For longer periods of operation, intervals should be shortened.

5-10. INTRODUCTION.

5-11. The maintenance chapter also includes a table of assembly designations and a table of recommended test equipment. Special equipment is covered in Paragraphs 5-3 through 5-8. An in-cabinet performance check and test care are also provided to be used: a) as part of an incoming inspection check of instrument specifications; b) periodically, for instruments used in systems where maximum reliability is required; c) as part of a troubleshooting procedure, and d) after repairs or adjustments, before returning instrument to regular service. Circuit adjustments are covered in Paragraphs 5-18 through 5-33. A troubleshooting procedure is given in Paragraph 5-34. Exploded views of the tuning cavity and harmonic generator assembly are contained in the Repair Parts and special tools list.

Table 5-1. Assembly Designations

A1	PHASE DETECTOR
A2	10 MHz OSCILLATOR
A3	50 MHz MULTIPLIER/AMPLIFIER
A4	200 MHz MULTIPLIER/AMPLIFIER
A5	HARMONIC GENERATOR
A6	MIXER-CAVITY
A7	VIDEO AMPLIFIER
A8	PRESALER
A9	CONTROL CIRCUIT
A10	GATE TIME EXTENDER

5-12. TEST EQUIPMENT.

5-13. GENERAL. Recommended test equipment is listed in Table 5-3. Three special extender boards are required. They are described in Paragraphs 5-14 through 5-17.

5-14. SPECIAL EXTENDER BOARDS. Three modified extender boards are needed to perform the adjustment procedures on assemblies A1, A2, A3, and A4. Construction of the three boards is described in the following paragraphs. Table 5-2 lists the type of modified extender board needed for each assembly.

Table 5-2. Extender Boards

ASSEMBLY	EXTENDER BOARD
A2 10 MHz Oscillator	Type 1
A3 50 MHz Mult./Amp.	Type 2
A4 200 MHz Mult./Amp.	Type 3
A9 Control Circuit	Standard Extender

5-15. TYPE 1 EXTENDER BOARD. This board consists of a standard extender board with a "BNC" connector mounted as shown in Figure 5-1. Contact pin S has been bent away from the board. Contact pin R has been bent away from the board and is not connected. A wire goes from pin S to the "BNC" center contact and then to contacts S and R. A 10K ohm pot is connected between pin L and ground. The center contact is connected to pin N.

NOTE

The sections of conductor that have been removed are from conductors N, R, and S.

Figure 5-1. Type 1 Extender Board

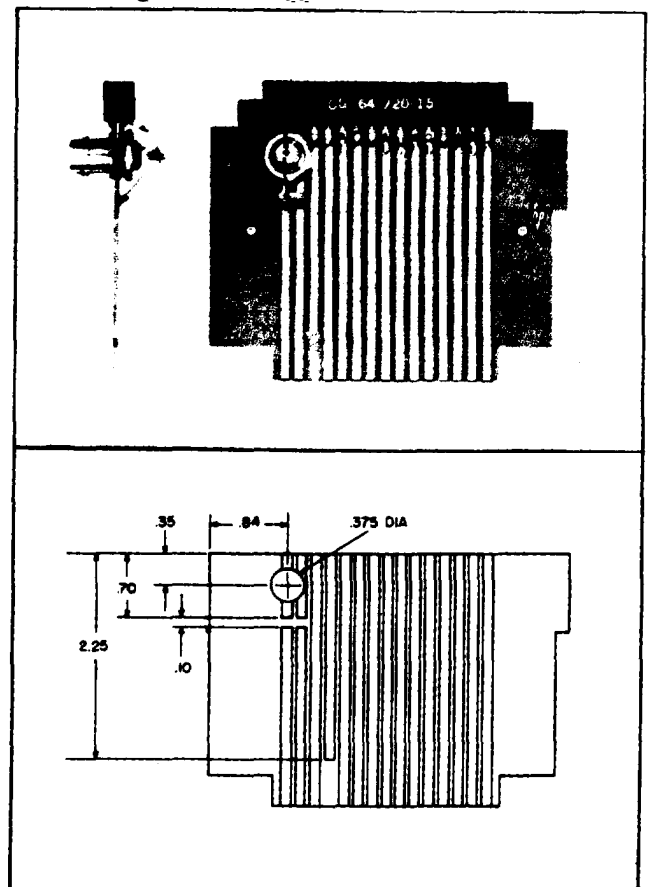

Table 5-3. Recommended Test Equipment

INSTRUMENT	CHARACTERISTICS	RECOMMENDED TYPE
Electronic Counter	Range: 50 MHz Sensitivity: 100 mV	HP Model 5245L
Sweep Oscillator	Range: 3.0 to 12.4 GHz Output: -7 dBm leveled	HP Model 8690 with 8692B/8693B/8694B
Test Oscillator	Range: 1 MHz to 10 MHz Output: 5 mV	HP Model 651B
VHF Oscillator	Range: 10 MHz to 201 MHz Output: 5 mV	HP Model 3200B
Quartz Oscillator	Range: 1 MHz and 5 MHz sine wave Accuracy: $\pm 5 \times 10^{-10}$ /24 hours	HP Model 107BR
Power Meter	Range: 3.0 GHz to 12.4 GHz	HP Model 431C
Thermistor Mounts	Range: 3 GHz to 12.4 GHz Power Range: 1 μ W to 10 mW Max SWR: 1.5:1	HP Models S486A/ G486A/J486A/X486A
Frequency Synthesizer	Range: 0.8 GHz to 12.4 GHz Power Input: 1 dBm	HP Model 2654A
Signal Generator	Range: 10 GHz to 12 GHz Output: +3 dBm	HP Model 626A
Waveguide Directional Couplers	Coupling Factor: 10 dBm	HP Models S752C/ G752C/J752C/X752C
Waveguide to Coax Adapters	Max SWR: 1.25:1	HP Models S281A/ G281A/J281A/X281A
Coax Attenuator	Attenuation Range: 0 to 80 dB in 10 dB steps	HP Model 355D
Coax Attenuator	Attenuation Range: 0 to 12 dB in 1 dB steps	HP Model 355C
Coax Directional Coupler	Frequency Range: 215 to 450 MHz Attenuation: 20 dB	HP Model 774D
Crystal Detector	Frequency Range: 10 MHz to 12.4 GHz	HP Model 423A
Oscilloscope	50 MHz Bandwidth, dual trace plug-in, external sync capability	HP Model 175A with HP 1750B & 1780A
Power Supply	+13V and -15V, 500 ma	HP Model 6205B
DC Voltmeter	0 V to ± 50 V, 10 megohm input impedance 1% accuracy	HP Model 412A
RF Millivoltmeter	Voltage Range: 10 mV to 10 V rms Frequency Range: 500 kHz to 1 GHz	HP Model 411A
50 ohm Coax Termination	SWR: less than 1.05:1	HP Model 908A
Extender Cable	50 pin	HP Model 10506B
Extender Board	15 pin (4 required)	HP Part No. 05245-6022

5-16. TYPE 2 EXTENDER BOARD. This board consists of a standard extender board with a "BNC" connector mounted as shown in Figure 5-2. Contact pin A has been bent away from the board. A wire is connected from pin A to the "BNC" center contact.

5-17. TYPE 3 EXTENDER BOARD. This board consists of a standard extender board with a 510 ohm resistor added to it. Pin A is bent away from the board. The 510 ohm resistor is connected between pin A and conductor A on the board.

NOTE

All tests are with \bar{h} Model 5255A connected to \bar{h} Model 5245L Electronic Counter.

5-18. CIRCUIT ADJUSTMENTS.

5-19. PHASE DETECTOR A1.

5-20. The following procedure adjusts the phase detector assembly A1 for maximum output.

- a. Set up equipment as shown in Figure 5-3.
- b. Set oscilloscope controls as follows:

VERTICAL INPUTDC
 VERTICAL SENSITIVITY 5 V/cm
 TIME BASE5 msec/cm
 TRIGGERINGINT

Figure 5-2. Type 2 Extender Board

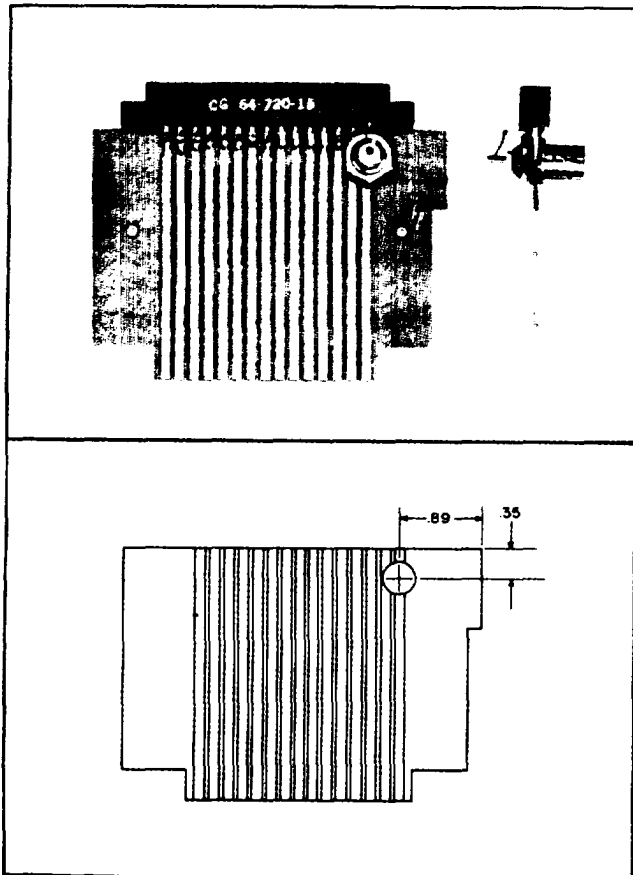
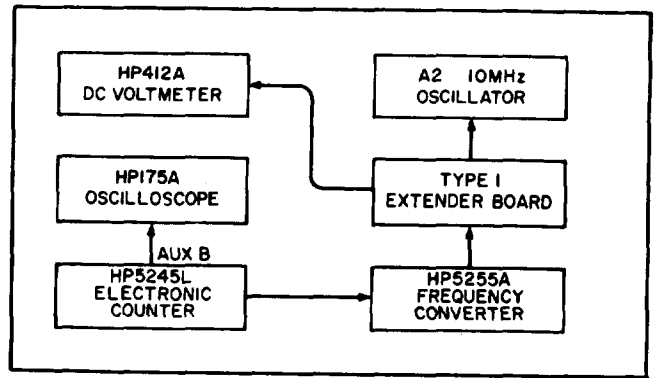

Figure 5-3. Phase Detector Test Setup



- c. Set Counter controls as follows:

SENSITIVITY PLUG-IN
 FUNCTION FREQUENCY

- d. Connect the DC Voltmeter to pin N of the extender board.

- e. Adjust the 10K ohm pot on the extender board until the DC level at pin N is +2 V.

- f. Connect the DC Voltmeter to the BNC connector on the modified extender board.

- g. Tune A1L1 for maximum output. The DC Voltmeter should read greater than +7 volts. The amplitude observed on the oscilloscope should be greater than 10 volts peak-to-peak.

5-21. 10 MHz OSCILLATOR A2.

5-22. The following procedure adjusts 10 MHz oscillator for proper operation.

- a. Connect equipment as shown in Figure 5-4.
- b. Set counter controls as follows:

SENSITIVITY1 V
 TIME BASE1 S
 FUNCTION FREQUENCY

Figure 5-4. 10 MHz Oscillator Test Setup

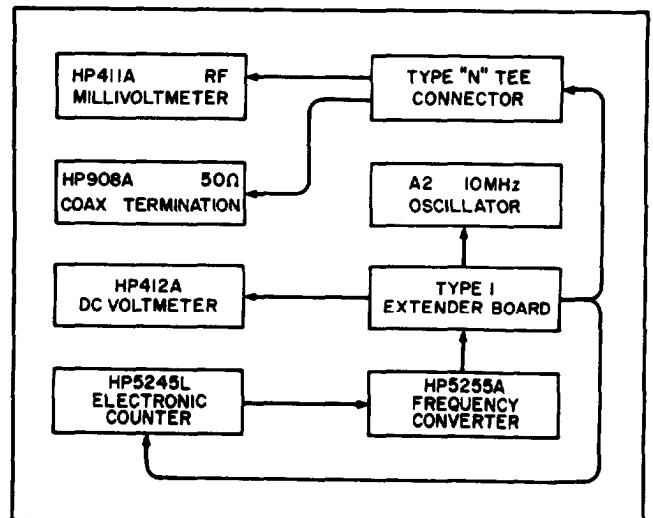

- c. Set the RF Millivoltmeter on the 1 V rms range.
- d. Set the DC voltmeter to +10V range.
- e. Connect the output of the oscillator (BNC connector) to the counter at RF Millivoltmeter.
- f. Connect the probe of the DC voltmeter to pin N.
- g. Adjust the 10K ohm potentiometer for a reading of +2 volts dc.
- h. Adjust A2C8 for a counter reading of 9999.350 MHz ±20 kHz.
- i. Adjust A2C9 for maximum output.
- j. Recheck the counter reading to be sure it did not change. If necessary, readjust A2C8 for correct reading.

5-23. 50 MHz MULTIPLIER/AMPLIFIER A3.

5-24. The following procedure adjusts the 50 MHz Multiplier/Amplifier assembly for maximum output.

- a. Remove A4 200 MHz Multiplier /Amplifier assembly 05255-6001.
- b. Connect equipment as shown in Figure 5-5.
- c. Set counter controls as follows:
 SENSITIVITY PLUG -IN
 TIME BASE 10 ms
 FUNCTION FREQUENCY
- d. Set oscilloscope controls as follows:
 VERTICAL INPUT AC
 VERTICAL SENSITIVITY5 V/cm
 TRIGGERINGINT
 TRIGGER SLOPENEG
- e. Set RF Millivoltmeter to 3 V rms range.

Figure 5-5. 50 MHz Multiplier/Amplifier Test Setup

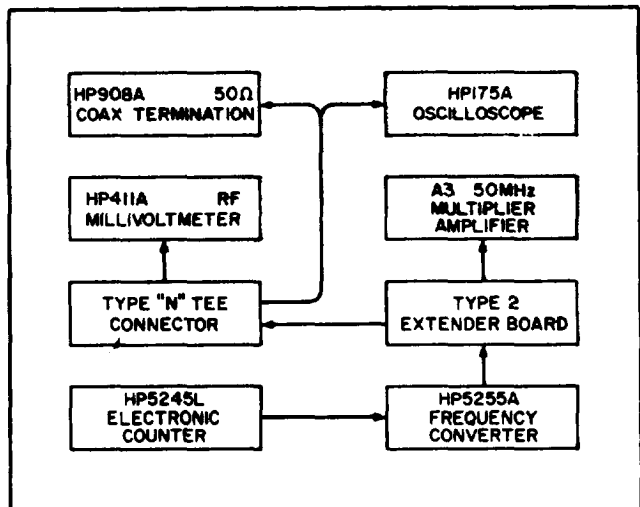

- f. Tune capacitors A3C3, A3C7, A3C11, A3C14, and A3C17 for maximum output.

NOTE

Observe envelope on oscilloscope. Make sure that no quenching occurs.

- g. Repeat adjustment of capacitors back and forth several times to get absolute maximum output. After adjustments are complete, replace A4 200 MHz Multiplier/Amplifier assembly,

5-25. 200 MHz MULTIPLIER/AMPLIFIER A4.

5-26. The following procedure adjusts the 200 MHz Multiplier/Amplifier assembly A4 for maximum output. Disconnect the output from A4 pin 5 going to the harmonic generator assembly A5. Connect the equipment as shown in Figure 5-6. Connect the RF Millivoltmeter to the output of A4 by using the selectroadapter. This is connected to the cable that normally goes to the harmonic generator A5. Tune capacitors A4C2, A4C5, A4C8, A4C10, A4C13, A4C15, and A4C18 for maximum output.

NOTE

The preceding adjustments are very critical and should be done very carefully,

- 5-27. Repeat the tuning procedure several times to ensure absolute maximum output. C18 may have more than 1 peak. Set it at the peak giving maximum output. The output signal amplitude from A4 is controlled by A4R12. During alignment, A4R12 should be set full clockwise (maximum output). When alignment is completed, A4R12 is adjusted for a 4 volt signal output. This prevents damage to the harmonic generator when A4 is reconnected to the unit. The final setting of A4R12 should be made with the harmonic generator assembly connected: Monitor the bias on the harmonic generator test point with a VTVM (Ⓢ 412A) and set A4R12 to give slightly less than maximum "bias (usually between -8 and -12 volts). Generally the bias will reach a maximum negative value then begin to return toward zero as A4R12 is continuously tuned toward maximum output. The 200 MHz drive should be slightly below that giving maximum negative bias.

Figure 5-6. 200 MHz Multiplier/Amplifier Test Setup

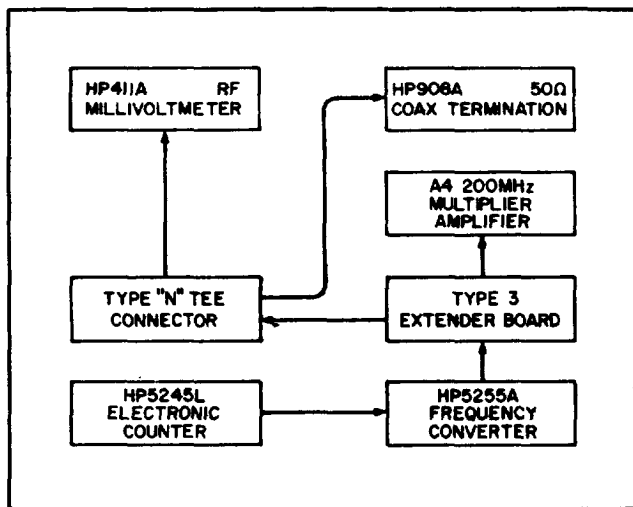

5-28. HARMONIC GENERATOR A5.

5-29. The following procedure aligns the harmonic generator matching assembly.

NOTE

This alignment should not be attempted unless there is good reason to believe that the matching assembly is not in alignment.

a. Remove the two screws holding the side plates to the front panel. Remove the two screws holding the bottom plate to the rear frame. Carefully separate the two halves of the plug-in.

b. Remove the cover from the harmonic generator.

c. Connect the 5255A plug-in to the counter with an extender cable.

d. Connect an oscilloscope to test point 1 on the harmonic generator A5.

e. Turn on power.

f. Adjust A5L1 about 1/16 inch down from the top of the coil form.

g. Slowly tune capacitor A5C2 while rapidly tuning capacitor A5C3 back and forth while looking for an absolute peak on the oscilloscope. (A5C2 may be tuned rapidly and A5C3 slowly.)

5-30. Another method of aligning the harmonic generator is using a reflectometer system. This is a very sensitive method and is tuned for a very sharp null.

a. Remove harmonic generator from 5255A plug-in.

b. Connect test equipment as shown in Figure 5-7.

c. Adjust the coil slug A5L1 to about 1 turn below the top of the coil form.

d. Using two tuning wands adjust A5C2 and A5C3 so that the reflected signal is less than 5 millivolts.

5-31. MIXER DIODE CHECK.

a. Take the plus lead from the mixer and connect center conductor to positive part of diode curve tracer or transistor checker.

b. Connect center conductor of RF input to mixer and ground of mixer to negative terminal of curve tracer or transistor checker.

c. Measure the current at 1 volt (since there is a resistive pad in series with the mixer diodes the forward conductance will appear to be less than that of the diodes alone). The current should be between 5 and 20 milliamps. With a 100K series protective resistor the reverse voltage may be measured.

d. Run the voltage out to 5 V or less or until the current reads 10 μ amps.

CAUTION

Do not exceed 5 volts or 10 microamps in the reverse direction. Do not use less than 100K protective resistor. The diode should take at least 3.5 V in the reverse direction and draw less than 10 μ amps at 3.5 V. Keep the reverse voltage on the diode only long enough to make the measurement.

When the positive or plus diode has been tested reverse the curve tracers polarity and check the negative diode in the same way.

5-32. CONTROL BOARD A9.

5-33. The following procedure checks the control board for proper operation. The initial test is made without connecting the 5255A plug-in to the counter.

a. Remove the top and side covers of the 5255A plug-in.

b. Connect the control board to the converter by using the extender board,

c. Disconnect the prescaler input from the video amplifier output.

d. Connect test equipment as shown in Figure 5-8.

Figure 5-8. Control Assembly Test Setup

Figure 5-7. Harmonic Generator Test Setup

e. Set oscilloscope controls as follows:

VERTICAL SENSITIVITY1 V/cm
VERTICAL INPUT DC
HORIZONTAL TIME BASE 1 V/cm
HORIZONTAL INPUT DC
CHANNEL A Polarity +
CHANNEL B Polarity

f. Set the controls of the Jerrold sweep generator as follows:

FREQUENCY 212 MHz
BAND SELECTOR VHF
ATTENUATOR.0 dB
RF OUTPUT maximum clockwise
SWEEP WIDTH maximum clockwise

g. Set DC Voltmeter to -1 V range. Connect negative lead to A9Q1 collector. Connect positive lead to A9Q2 collector.

h. Adjust A9R4 for an output voltage of -.6 volts \pm .1 volt dc.

i. Remove the DC Voltmeter probes.

j. Connect scope probe CHANNEL B to the collector of A9Q1; CHANNEL A to the collector of A9Q2.

k. Connect the Jerrold sweep generator RF output to the prescaler input.

l. Adjust the horizontal gain of the oscilloscope so the display is 10 cm wide. Move the position control so zero input (vertical disconnected) is exactly on the center line.

m. Adjust the phasing control on the sweeper by pushing the knob in and tuning until the trace and the retrace coincide. Pull the knob back out.

n. Adjust A9C1 and A9C4 so that the trace crossover line is very steep (the steeper the better) on the right side above crossover. The curve is always greater than 1/2 volt positive to at least 390 MHz.

o. Turn the sweep width fully counterclockwise and push the phasing knob in. Disconnect the sweeper from the prescaler input and connect it to the AUX IN connector on the front panel of the 5255A plug-in.

p. Reconnect the prescaler input to the video amplifier output.

q. Remove the DC power supply and connect the 5255A plug-in to the counter by an extender cable.

r. Set counter controls as follows:

SENSITIVITY PLUG-IN
 TIME BASE1 ms
 FUNCTION FREQUENCY

s. Turn counter on.

t. Change the frequency of the sweep generator until the counter starts reading (the needle of the meter moves into the green area). The reading should be 212 MHz \pm 1 MHz. If reading is incorrect repeat test procedure.

5-34. TROUBLESHOOTING.

5-35. The following procedure applies when one of these conditions is present:

- a. No meter reading for a microwave input.
- b. Low sensitivity indicated on meter.
- c. Incorrect readings.

Figure 5-9. Troubleshooting Block Diagram

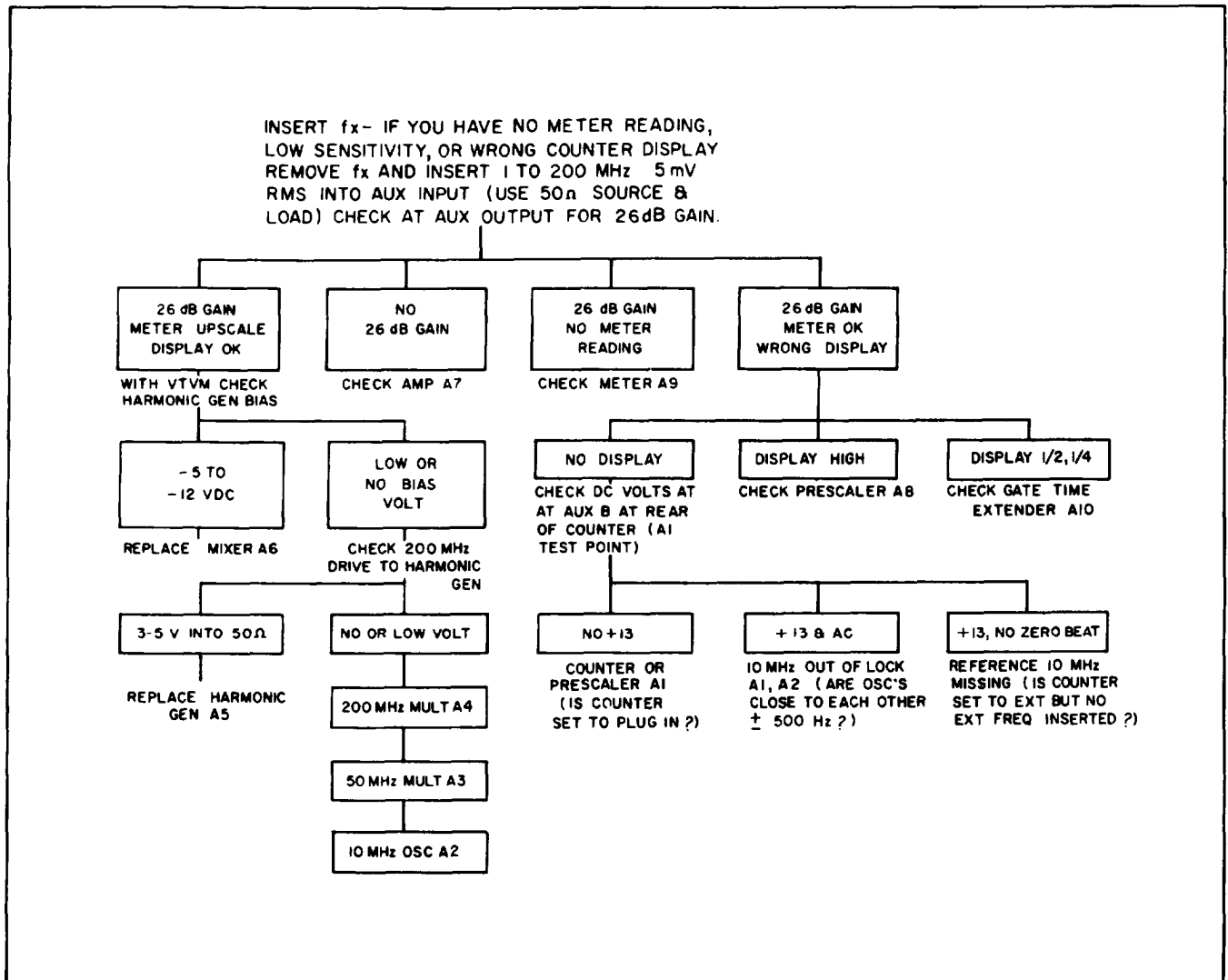

Table 5-4. Troubleshooting Procedure

1. Disconnect main input, check if auxiliary input operates correctly.
 - a. If not, check gain between Auxiliary Input and Auxiliary Output with a signal between 1 MHz and 200 MHz. Gain should be approximately 26 dB (50 ohm source and load) for low level (approximately 2-5 mV) input.
 - b. If amplifier gain is correct but the meter does not move upscale the meter circuitry is probably defective.
 - c. If the gain is correct and the meter moves upscale but the counter display is not correct, the prescaler or gate time extender (or the counter) may be defective.
 - 1) If the display is 1/2 or 1/4 of the correct frequency the gate time extender is probably not operating correctly.
 - 2) If the display is higher than the correct value the prescaler may be the cause.
 - d. If the gain is correct and the meter reads upscale but there is not display, check the dc voltage at the AUX B output of the counter.
 - 1) If the voltage is +13 the prescaler is held from operating by a No Lock signal from the control board assembly.
 - a) If a low frequency ac signal is present at AUX B in addition to the +13 volts, the 10 MHz oscillator in the plug-in is out of lock from the 10 MHz of the counter. The counter oscillator or the plug-in oscillator may be out of specifications, or an off-frequency external standard may be connected to the counter. (The lock range of the system is approximately +500 Hz at 10 MHz.)
 - b) If there is a +13 signal at AUX B but there is no large beat note present, the reference 10 MHz may be missing. (The counter may be set to EXT reference with no external reference connected.)
 - 2) If zero, the counter may not be set to plug-in mode, the counter may be defective or the prescaler assembly may have failed.
 - e. If the auxiliary input operates in some parts of its frequency range but does not operate even with reduced sensitivity in other parts of its frequency range the control board may be defective or misaligned.
2. If auxiliary input operation is correct (but not main input), using a VTVM check the bias on the harmonic generator assembly test point. (This test point may be reached by removing the machine screw on top of the harmonic generator assembly.) This test point should be between approximately -5 and -12 volts dc.
 - a. If the bias is correct, the difficulty is probably in the mixer.
 - b. If there is no bias, check the 200 MHz drive to the harmonic generator assembly. It should be approximately 3-5 volts rms into 50 ohms.
 1. If there is no bias, but if there is adequate drive, the harmonic generator is probably defective and the assembly should be replaced.
 2. If there is no 200 MHz drive present, check first the 200 MHz multiplier amplifier assembly then the 50 MHz multiplier assembly then the 10 MHz oscillator, in that order.

Table 5-5. In-Cabinet Performance Check

1. **RANGE:** As a converter: 3 to 12.4 GHz
As a prescaler: 1 to 200 MHz

AS A CONVERTER (Input 3 to 12.4 GHz):

a. Set Counter controls as follows:

SAMPLE RATE	slightly clockwise out of POWER OFF
SENSITIVITY	PLUG-IN
TIME BASE	1 ms
FUNCTION	FREQUENCY

b. Connect HP Model 8692A Signal Generator CAL RF POWER OUTPUT connector to the 5255A Converter INPUT 3-12.4 GHz connector. Set Generator output level to -7 dBm.

c. Vary frequency from 3.0 GHz to 4.0 GHz, keeping output constant at -7 dBm. Counter display plus Converter dial reading should properly indicate frequencies in this range. (Converter is tuned from low end of dial for first maximum indication on Level Indicator.)

Figure 5-10. Frequency Range Check

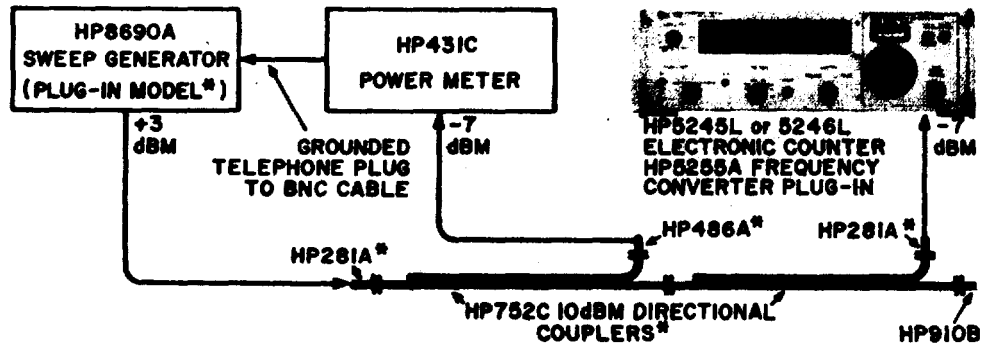

* SEE TABLE 5-3 FOR MODELS NEEDED TO COVER G THROUGH X BANDS

d. Substitute the HP Model 8693A Signal Generator for the 8692A using hookup in Figure 5-10 above. Set Generator for CW operation.

e. Vary frequency from 4.0 GHz to 8.0 GHz, keeping output constant at -7 dBm. Counter display plus Converter dial reading should properly indicate frequencies in this range.

f. Substitute the HP Model 8694A Signal Generator for the 8693A, using hookup in Figure 5-10. Set the Generator output for a -7 dBm reading on the HP Model 431C Power Meter.

g. Vary frequency from 8 GHz to 12.4 GHz, keeping output constant at -7 dBm. Counter display plus Converter dial reading should properly indicate frequencies in this range.

AS A PRESCALER (AUX IN 1 to 200 MHz):

a. Set Counter as follows:

SAMPLE RATE	slightly clockwise out of POWER OFF
SENSITIVITY	PLUG-IN
TIME BASE	1S
FUNCTION	FREQUENCY

b. Connect HP Model 651A Signal Generator OUTPUT connector to 5255A Converter AUX IN 1-200 MHz connector using a BNC "T" adapter. Monitor the Converter input with a HP Model 411A connected to the other BNC "T" port.

Table 5-5. In-Cabinet Performance Check (Cont'd.)

AS A PRESCALER (Cont'd.)

- c. Vary frequency from 1 MHz to 10 MHz, keeping output constant at 5 mV. Counter should properly display frequencies directly.
- d. Substitute HP Model 3200B for the 651A.
- e. Vary frequency from 10 MHz to 201 MHz, keeping output constant at 5 mV. Counter should properly display frequencies directly.

2. INPUT SIGNAL LEVEL: As a converter: 100 mV (INPUT 3-12.4 GHz)
As a prescaler: 5 mV (AUX IN 1-200 MHz)

Input signal level specifications are verified by procedure 1, RANGE check.

3. ACCURACY: same as basic counter

AS A CONVERTER (INPUT 3-12.4 GHz):

- a. Use hookup in Figure 5-11 to check measurement accuracy of measured frequencies in 3 GHz to 12.4 GHz range.

Figure 5-11. Measurement Accuracy Check

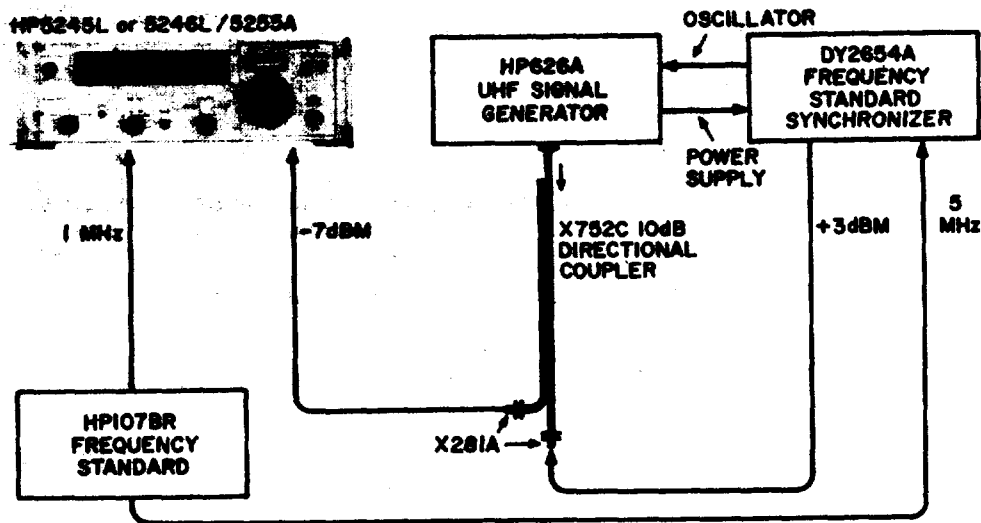

- b. Set Counter controls as follows:

SAMPLE RATE	slightly clockwise out of POWER OFF
SENSITIVITY	PLUG -IN
TIME BASE1 S
FUNCTION	FREQUENCY

- c. Set HP Model 626A controls as follows:

Frequency Dial	near 12 GHz
MOD SELECTOR	OFF
ZERO SET	adjust for power -monitor meter indication exactly on the ZERO SET index
MOD SELECTOR	CW
PWR SET	adjust for power -monitor meter indication exactly on the PWR SET index
OUTPUT ATTEN	3 dBm

Table 5-5. In-Cabinet Performance Check (Cont'd.)

ASA CONVERTER (Cont'd.)

- d. Adjust Generator frequency until lock occurs (DY 2654A I. F. LEVEL in green and PHASE METER centered). Check for proper lock by changing frequency dial slightly above and below setting; phase meter should move almost full scale + and - if lock is correct.
- e. Tune Converter from well below "unknown" frequency until first indication occurs in green on Level Indicator. Peak the Level Indicator reading.
- f. The Converter dial reading (GHz) plus the Counter reading (MHz) should be equal to Generator frequency (signal generator dial is $\pm 1\%$).

AS A PRESCALER (AUX IN 1-200 MHz):

- a. Set Counter as follows:

SAMPLE RATE slightly clockwise out of POWER OFF
 SENSITIVITY PLUG-IN
 TIME BASE 1 S
 FUNCTION FREQUENCY

- b. Connect series HP Model 355C and 355D Attenuators (set total attenuation for 30 dB) between 1 MHz OUTPUT STD FREQ connector at rear of Counter and connector AUX IN 1-200 MHz Converter.
- c. 5255A Level Indicator should read more than 3. Counter display should be 1 MHz ± 1 count.
- d. Increase attenuation in 1 dB steps until Level Indicator reads approximately 3. Counter should still display 1 MHz ± 1 count.
- e. Set Counter as in step a.
- f. Connect 3200B to AUX IN connector. Set series attenuators for a total attenuation of 62 dB. Set Generator for 201.00 MHz.
- g. Adjust attenuators for approximately 3 on Level Indicator. Counter should display 201.00 MHz ± 1 count.

CHAPTER 6

CIRCUIT DIAGRAMS

6-1. INTRODUCTION.

6-2. This section includes the following:

a. General Notes for Schematic Diagrams are given in Figure 6-1.

b. Block Diagram (Figure 6-2).

c. Schematic Diagrams and Component Location illustrations of Model 5255A circuits, assemblies and connectors in the order of their assembly designation (A1 through A10, Figures 6-3 through 6-8). These figures also include voltages.

6-3. The Block Diagram or any schematic diagram, when unfolded, can be used with any other part of this manual, or with the manual closed.

6-4. DC voltages are measured with a  Model 412A DC Voltmeter. Typical voltages are shown.

Figure 6-1. General Notes for Schematic Diagrams



REFERENCE DESIGNATIONS

REFERENCE DESIGNATIONS WITHIN ASSEMBLIES ARE ABBREVIATED. ADD ASSEMBLY NUMBER TO ABBREVIATION FOR COMPLETE DESCRIPTION.

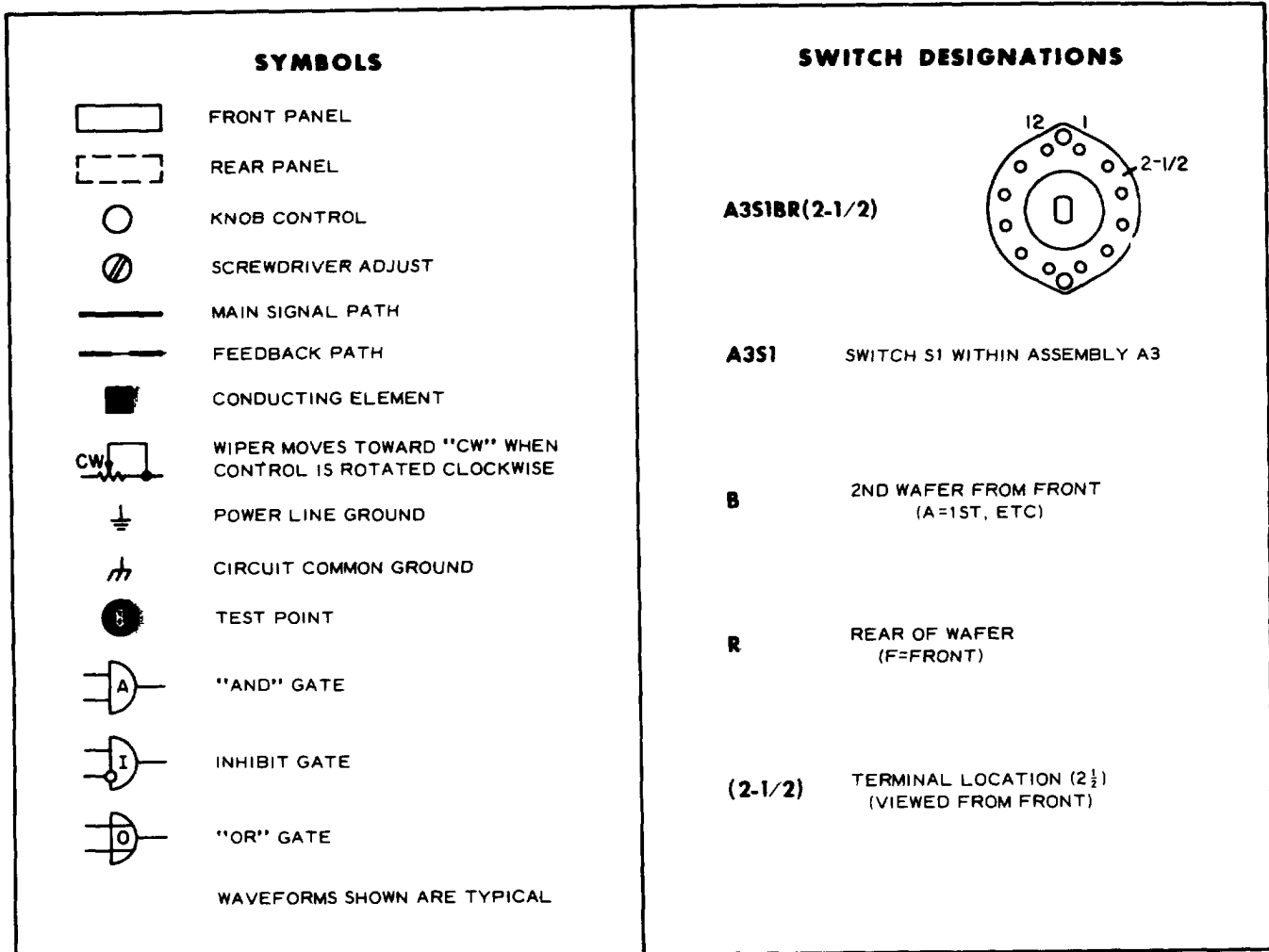
ASSEMBLY	ABBREVIATION	COMPLETE DESCRIPTION
A25	C1	A25C1
A25A1	CR1	A25A1CR1
NO PREFIX	J3	J3

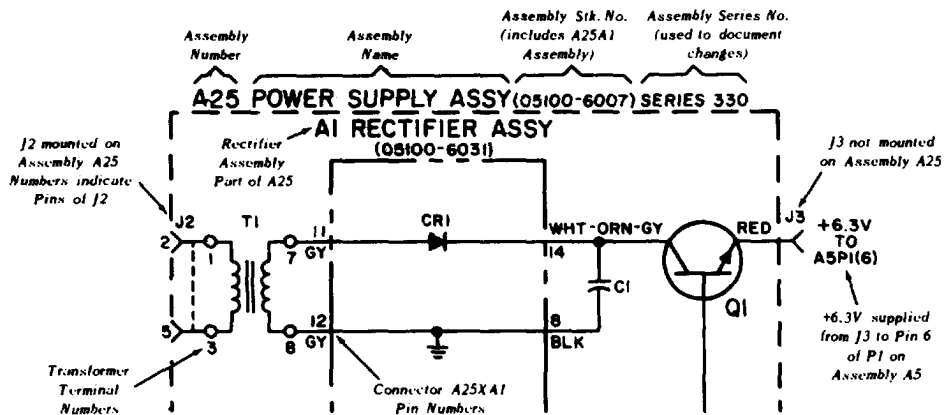

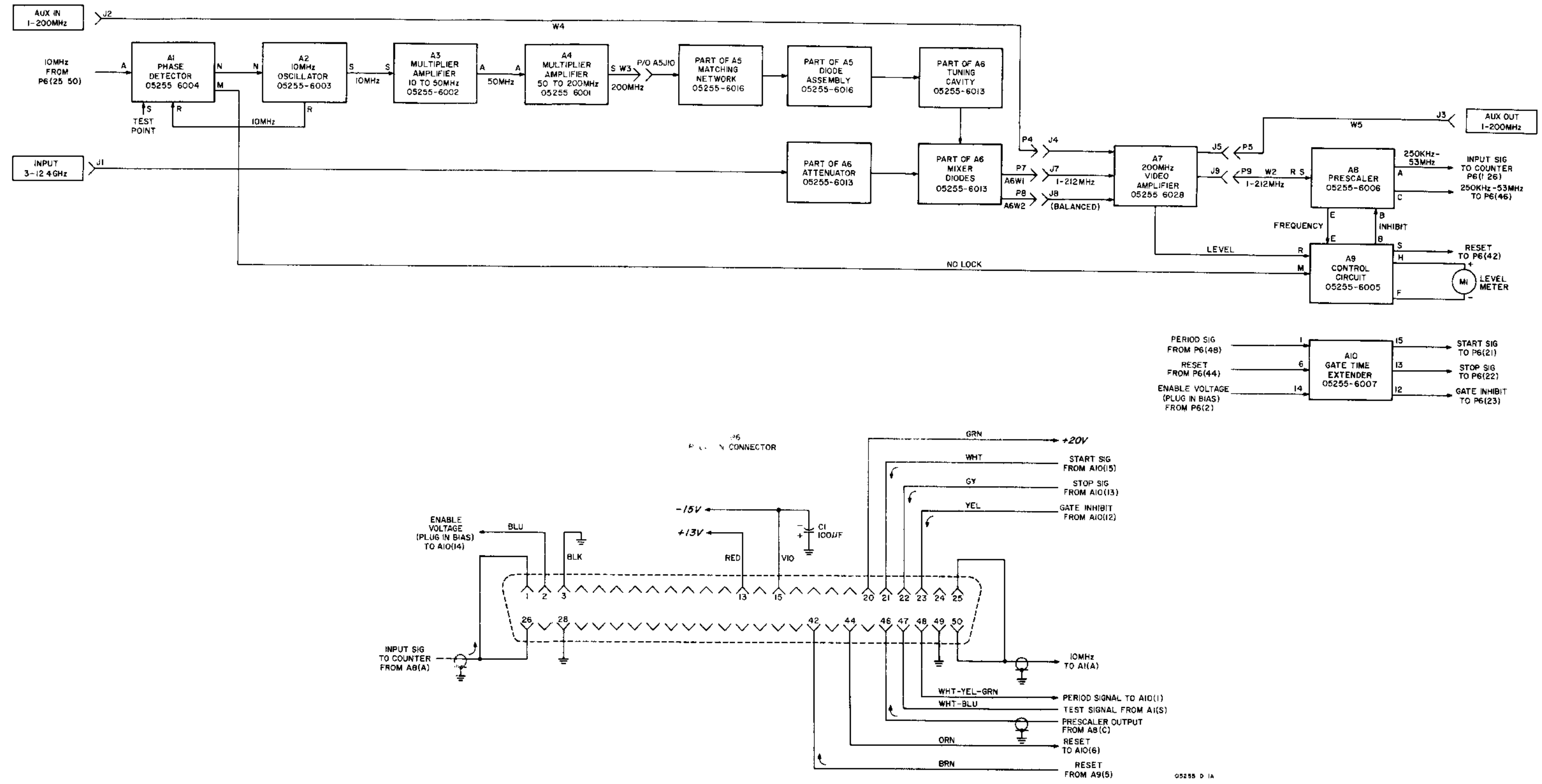
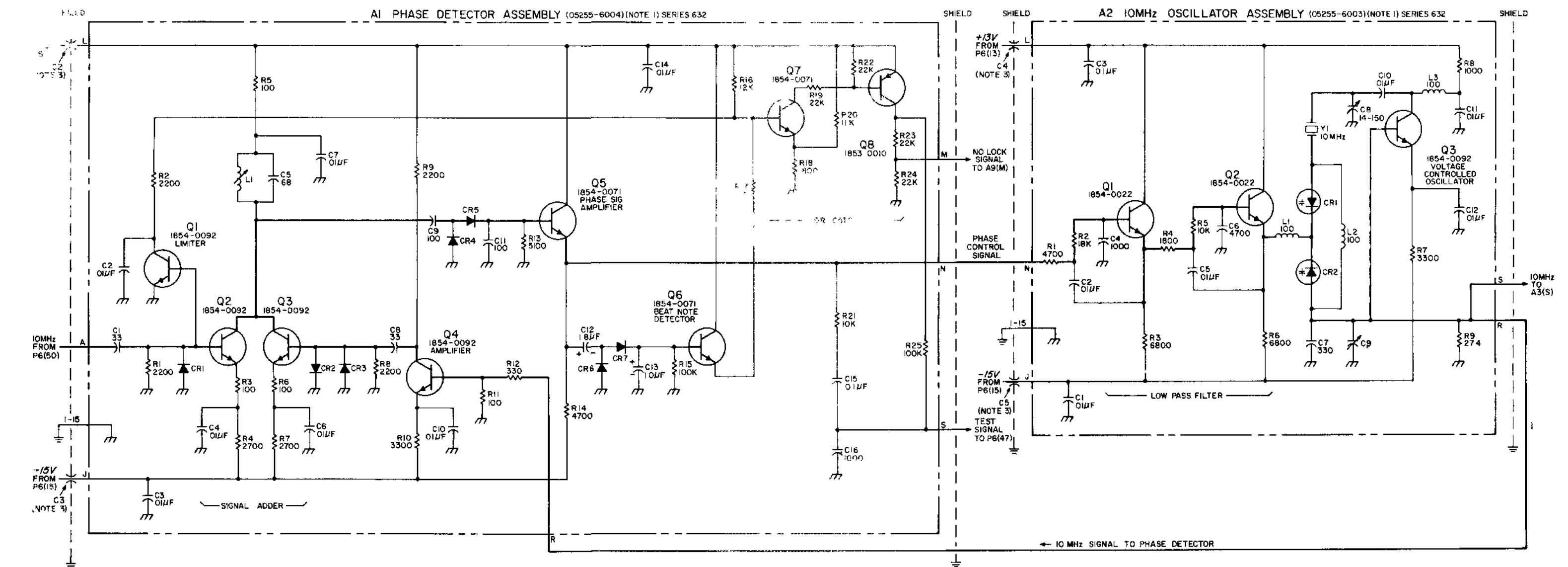
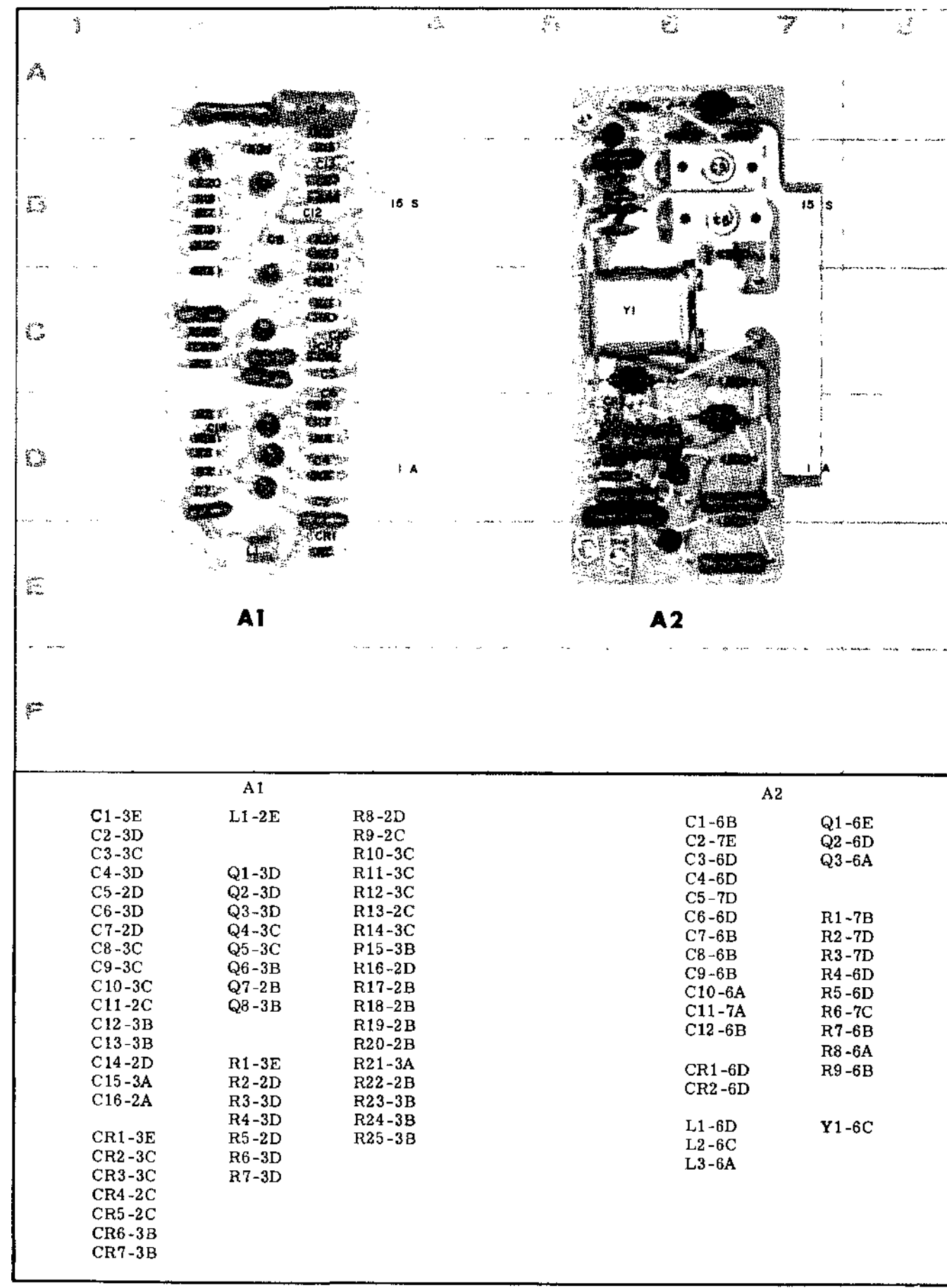

Figure 6-2. Block Diagram 6-3/6-4



NOTES
 1. REFERENCE DESIGNATIONS WITHIN THIS ASSEMBLY ARE ABBREVIATED. ADD ASSEMBLY DESIGNATION AS PREFIX TO FORM COMPLETE DESIGNATION.

2. UNLESS OTHERWISE INDICATED:
 RESISTANCE IN OHMS
 CAPACITANCE IN PICOFARADS
 INDUCTANCE IN MICROHENRIES

3. C2 THROUGH C5 ARE FEEDTHROUGH FILTER NETWORKS.

REFERENCE DESIGNATIONS

NO PREFIX	A1	A2
C2 - 5	C1 - 16 CR1 - 7 L1 - 8 Q1 - 25 R1 - 25	C1 - 12 CR1 - 2 L1 - 3 Q1 - 3 R1 - 9 Y1 - 9

05255 0-24

Figure 6-3. Phase Detector Assembly A1
 10 MHz Oscillator Assembly A2
 6-5/6-6

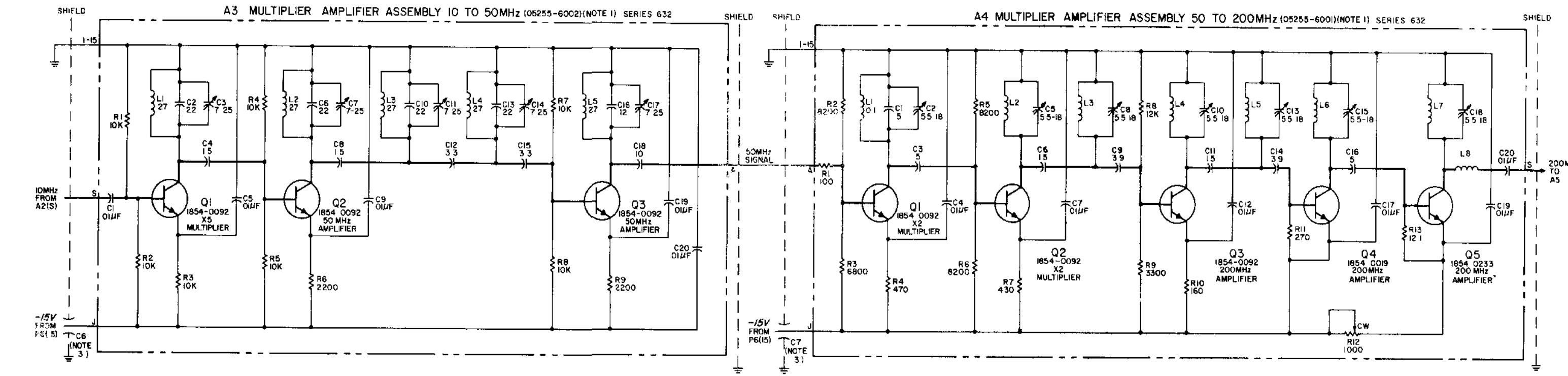
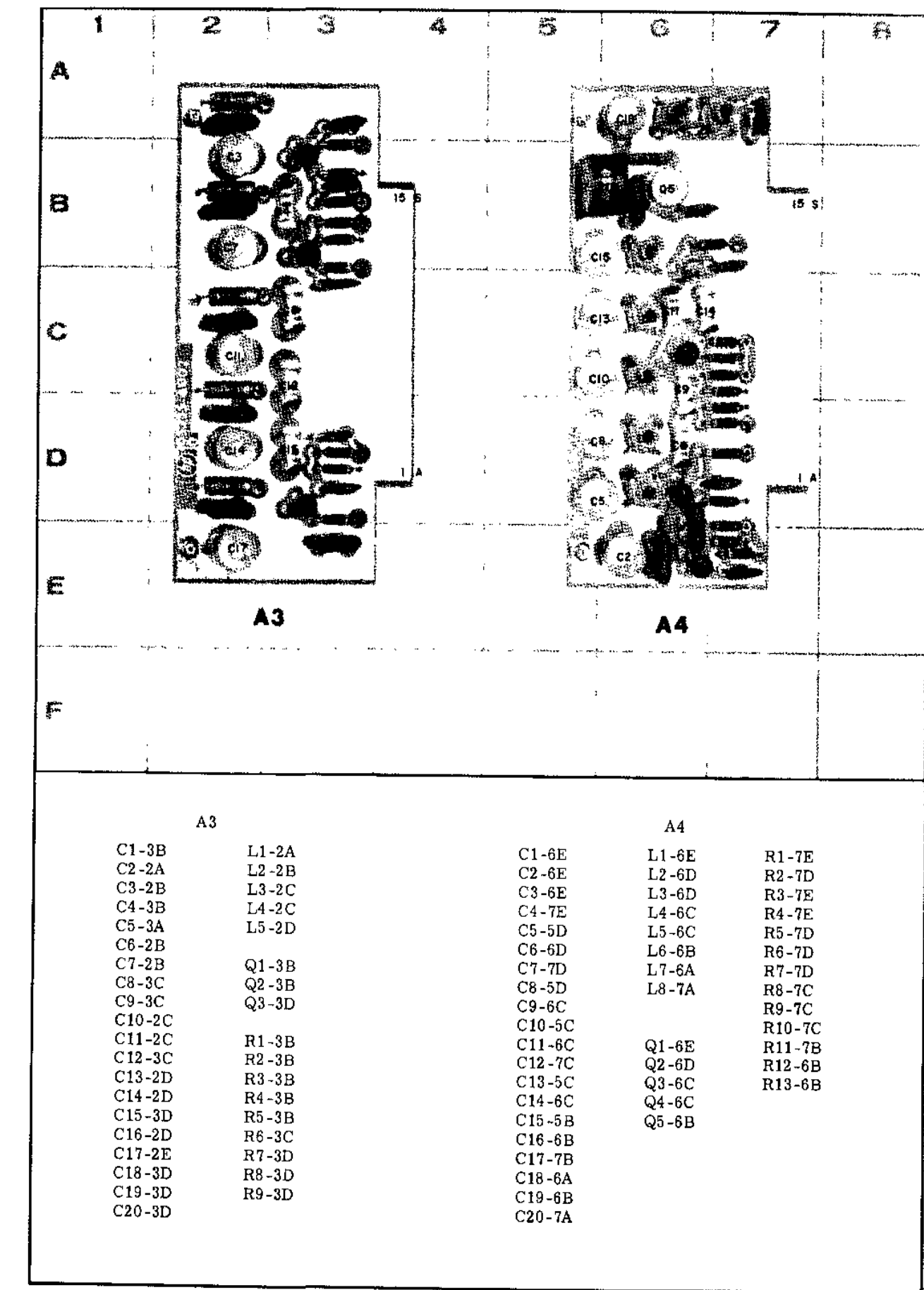

NOTES

- REFERENCE DESIGNATIONS WITHIN THIS ASSEMBLY ARE ABBREVIATED. ADD ASSEMBLY DESIGNATION AS PREFIX TO FORM COMPLETE DESIGNATION.
- UNLESS OTHERWISE INDICATED:
RESISTANCE IN OHMS
CAPACITANCE IN PICOFARADS
INDUCTANCE IN MICROHENRIES
- C6 AND C7 ARE FEED THROUGH FILTER NETWORKS.

REFERENCE DESIGNATIONS		
NO PREFIX	A3	A4
C6-7	C1-20 L1-5 Q1-3 R-9	C-20 L1-8 Q1-5 R1-13

Figure 6-4. 50 MHz Multiplier/Amplifier Assembly A3
200 MHz Multiplier/Amplifier Assembly A4

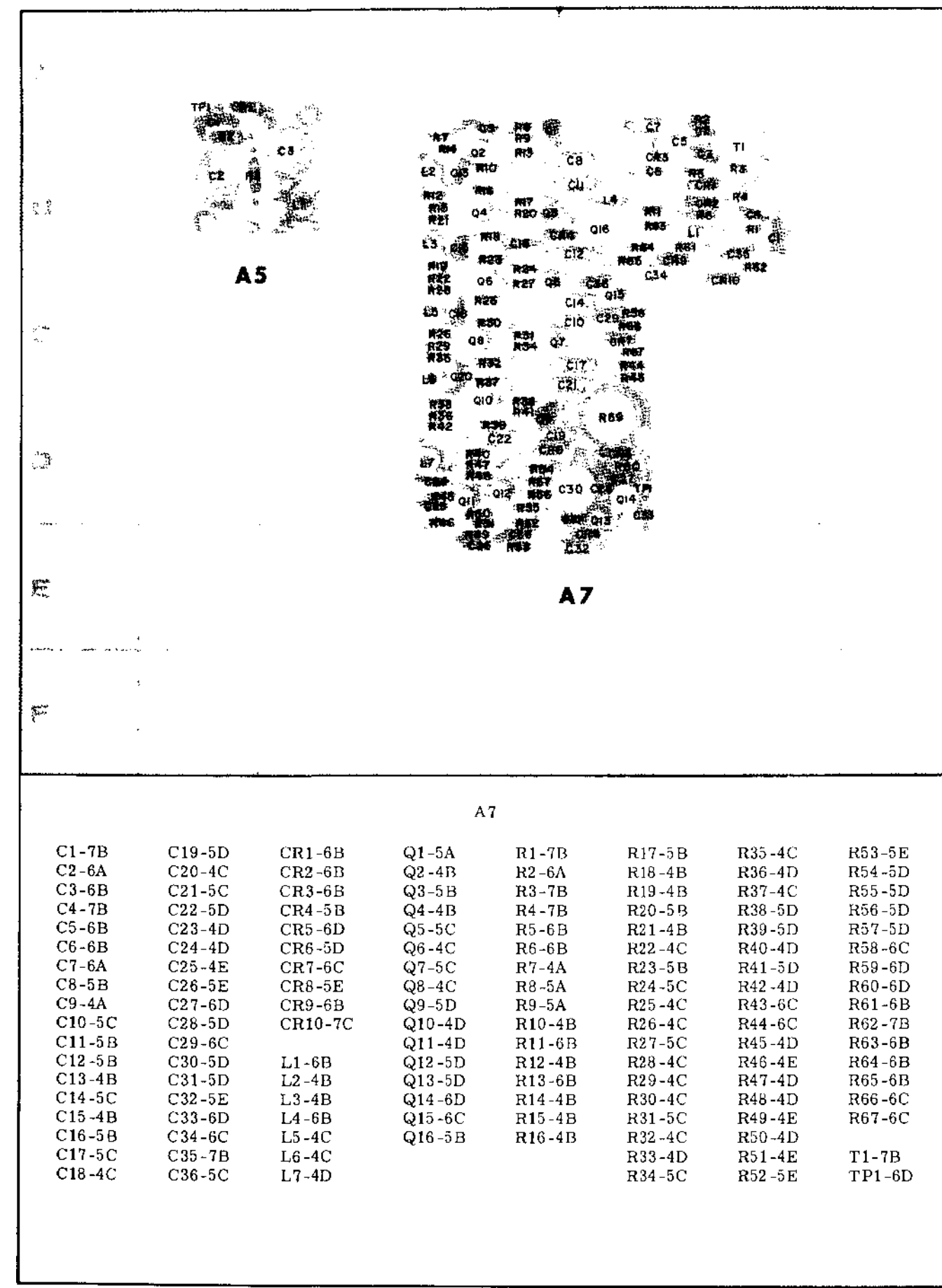

A7

C1-7B	C19-5D	CR1-6B	Q1-5A	R1-7B	R17-5B	R35-4C	R53-5E
C2-6A	C20-4C	CR2-6B	Q2-4B	R2-6A	R18-4B	R36-4D	R54-5D
C3-6B	C21-5C	CR3-6B	Q3-5B	R3-7B	R19-4B	R37-4C	R55-5D
C4-7B	C22-5D	CR4-5B	Q4-4B	R4-7B	R20-5B	R38-5D	R56-5D
C5-6B	C23-4D	CR5-6D	Q5-5C	R5-6B	R21-4B	R39-5D	R57-5D
C6-6B	C24-4D	CR6-5D	Q6-4C	R6-6B	R22-4C	R40-4D	R58-6C
C7-6A	C25-4E	CR7-6C	Q7-5C	R7-4A	R23-5B	R41-5D	R59-6D
C8-5B	C26-5E	CR8-5E	Q8-4C	R8-5A	R24-5C	R42-4D	R60-6D
C9-4A	C27-6D	CR9-6B	Q9-5D	R9-5A	R25-4C	R43-6C	R61-6B
C10-5C	C28-5D	CR10-7C	Q10-4D	R10-4B	R26-4C	R44-6C	R62-7B
C11-5B	C29-6C		Q11-4D	R11-6B	R27-5C	R45-4D	R63-6B
C12-5B	C30-5D		Q12-5D	R12-4B	R28-4C	R46-4E	R64-6B
C13-4B	C31-5D	L1-6B	Q13-5D	R13-6B	R29-4C	R47-4D	R65-6B
C14-5C	C32-5E	L2-4B	Q14-6D	R14-4B	R30-4C	R48-4D	R66-6C
C15-4B	C33-6D	L3-4B	Q15-6C	R15-4B	R31-5C	R49-4E	R67-6C
C16-5B	C34-6C	L4-6B	Q16-5B	R16-4B	R32-4C	R50-4D	
C17-5C	C35-7B	L5-4C			R33-4D	R51-4E	T1-7B
C18-4C	C36-5C	L6-4C			R34-5C	R52-5E	TP1-6D
		L7-4D					

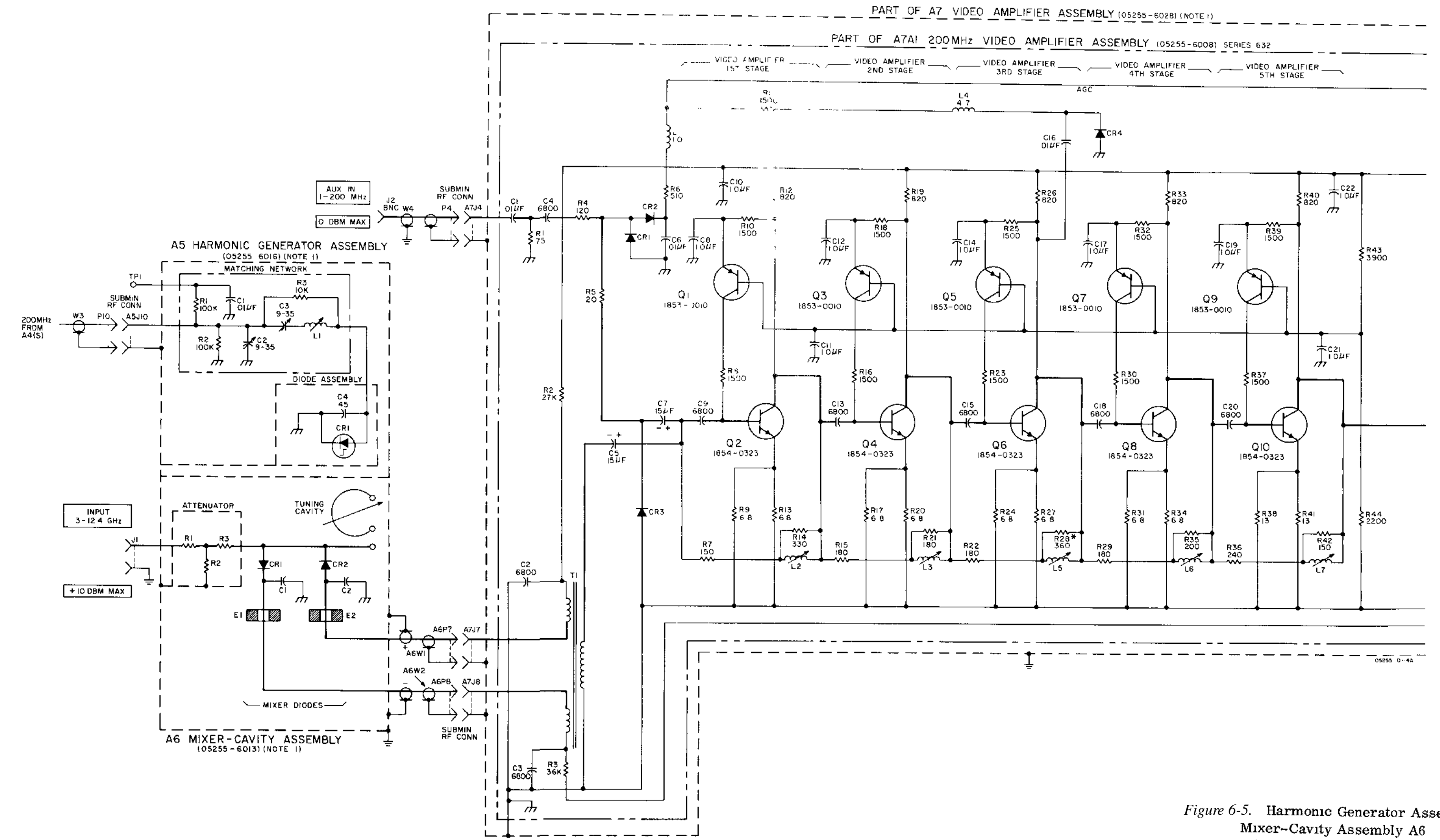
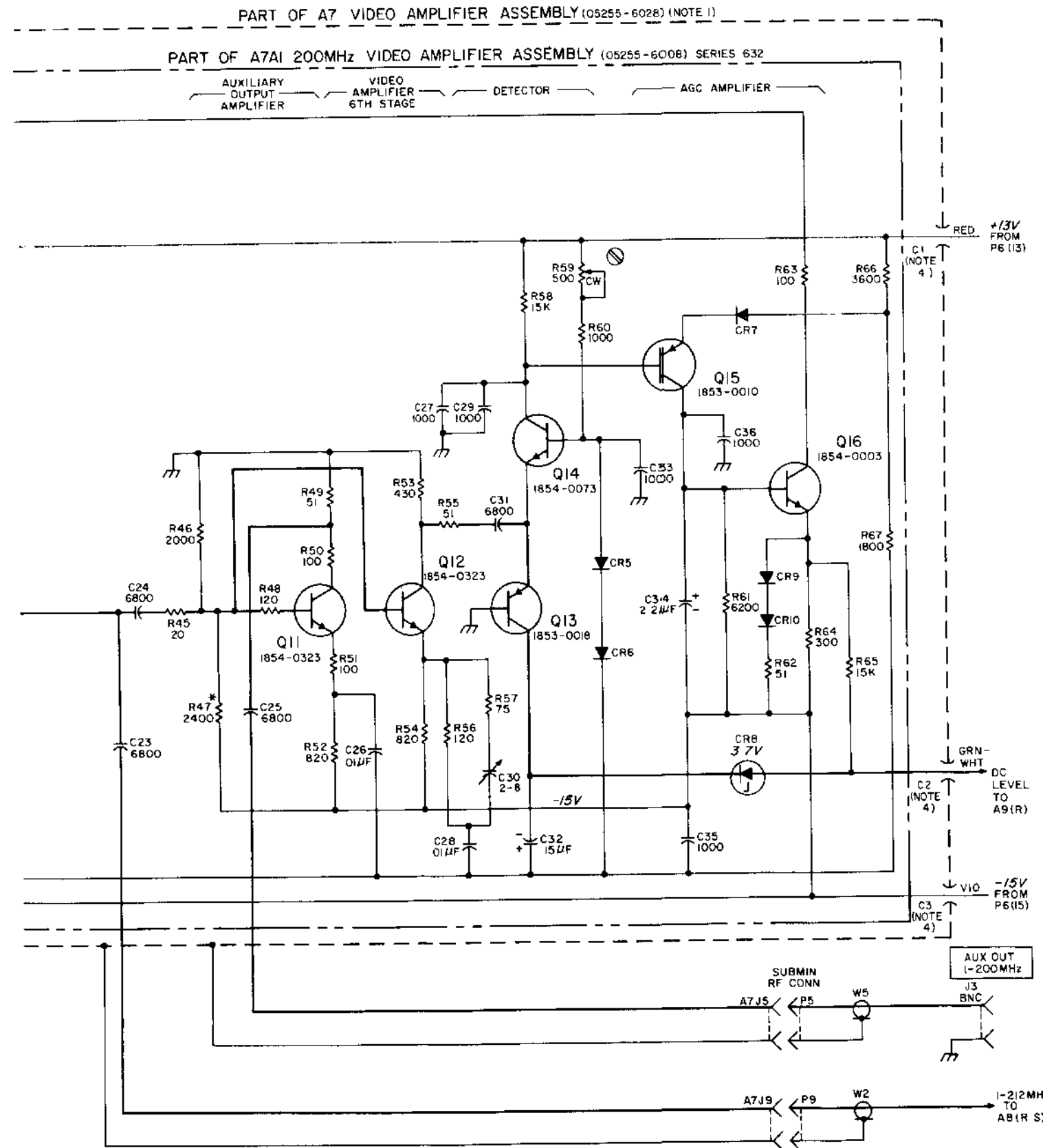

Figure 6-5. Harmonic Generator Assembly A5
Mixer-Cavity Assembly A6
Video Amplifier Assembly A7
(Sheet 1 of 2)



NOTES

- 1 REFERENCE DESIGNATIONS WITHIN THIS ASSEMBLY ARE ABBREVIATED. ADD ASSEMBLY DESIGNATION AS PREFIX TO FORM COMPLETE DESIGNATION.
- 2 UNLESS OTHERWISE INDICATED RESISTANCE IN OHMS CAPACITANCE IN PICO FARADS INDUCTANCE IN MICROHENRIES
- 3 ASTERISK (*) INDICATES SELECTED COMPONENT AVERAGE VALUES SHOWN
- 4 A7C1 THRU A7C3 ARE FEED THROUGH FILTER NETWORKS

REFERENCE DESIGNATIONS

NO PREFIX	A5	A6	A7A1	A7
J1-3	C1-4 CR1	C1-2 CR1-2 EI-2	C1-36 CR1-10	C1-3
P4-5 7-10	L1	P7-8	L1-7	J4-5-7-9
W2-5	R1-3 TP1	R1-3	Q1-16 R1-67 T1	

05255 D 6A
Figure 6-5. Harmonic Generator Assembly A5
Mixer-Cavity Assembly A6
Video Amplifier Assembly A7
(Sheet 2 of 2)
6-11/6-12

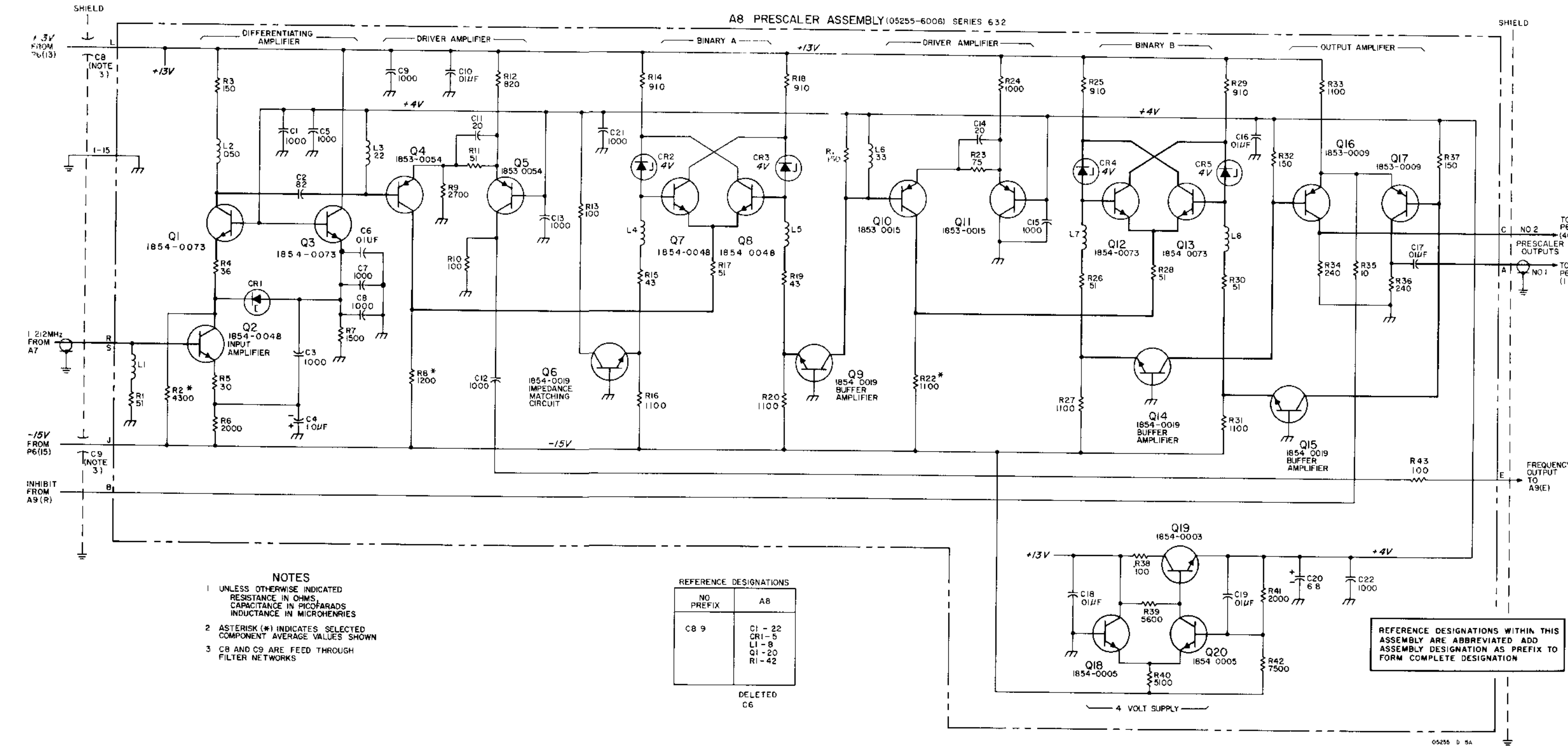
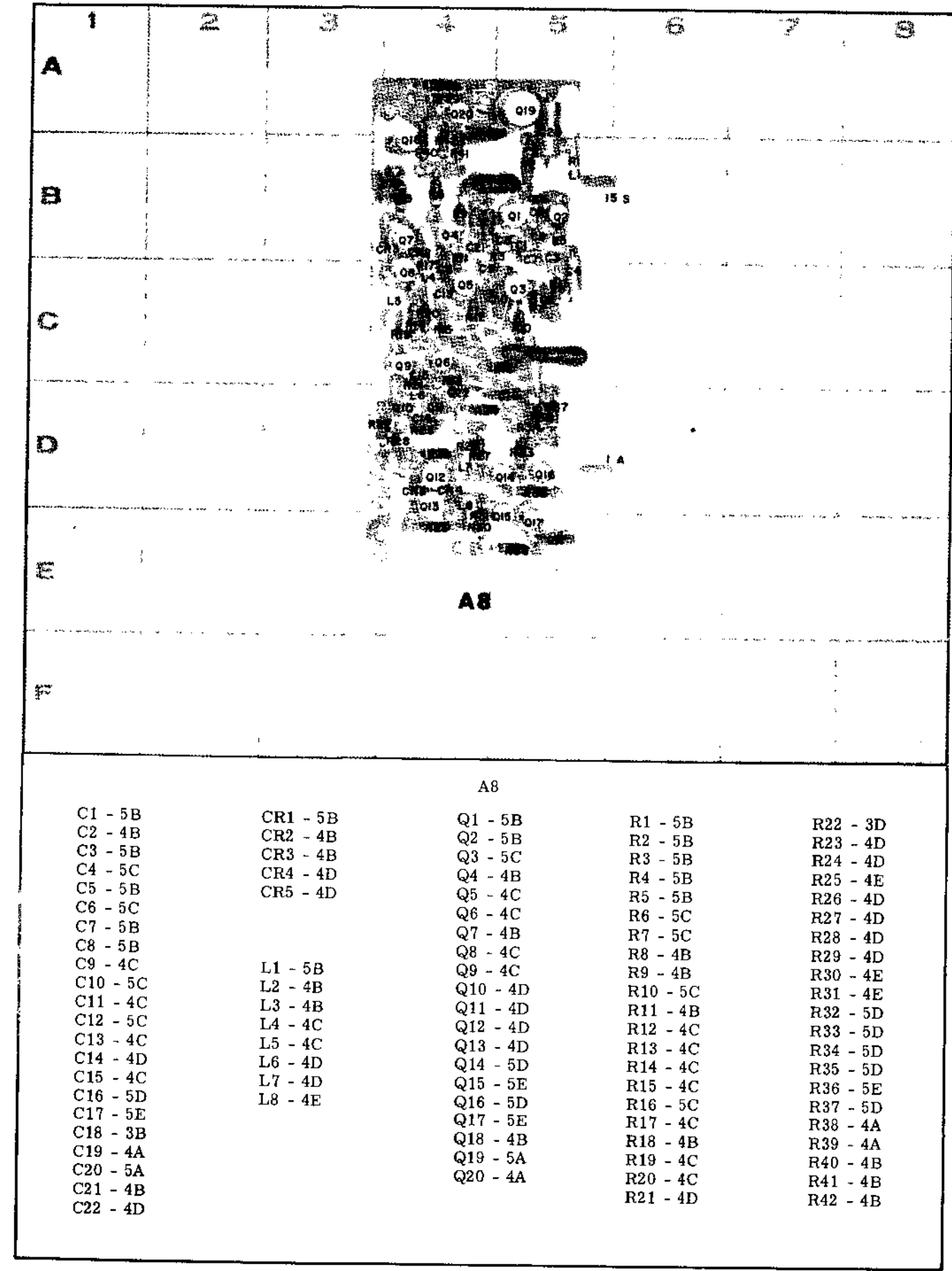
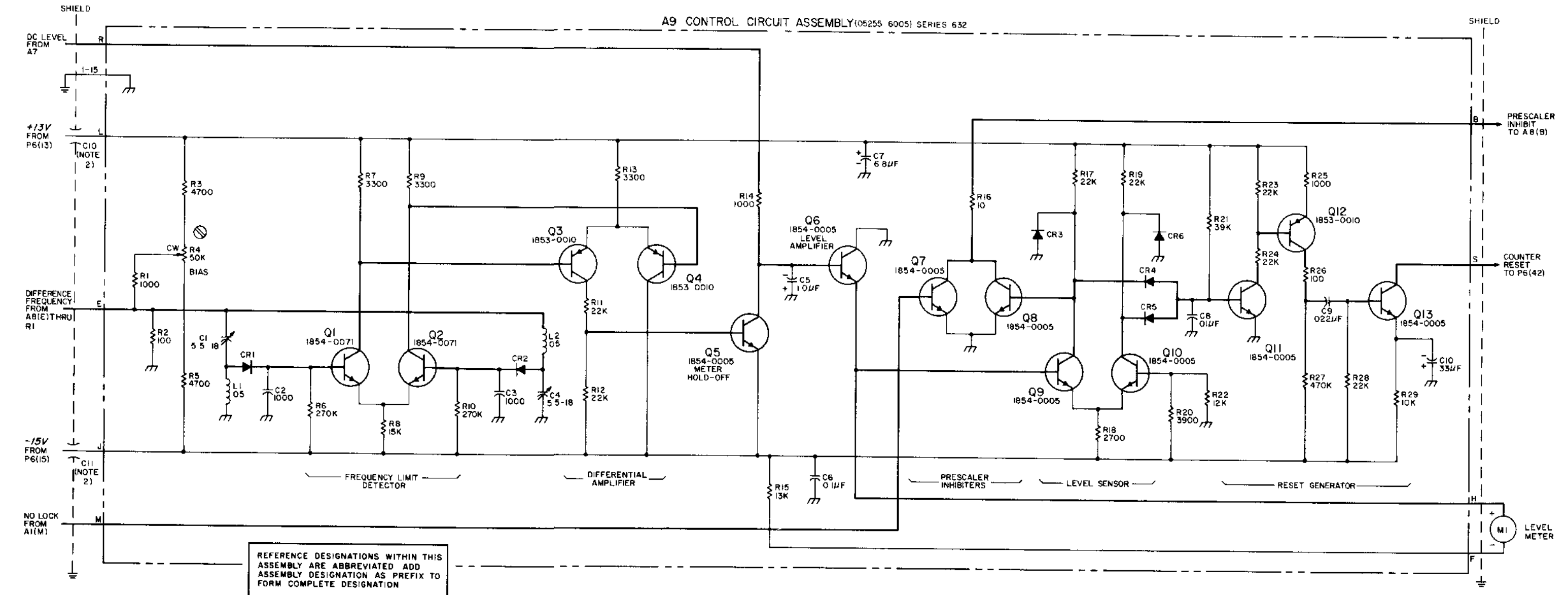
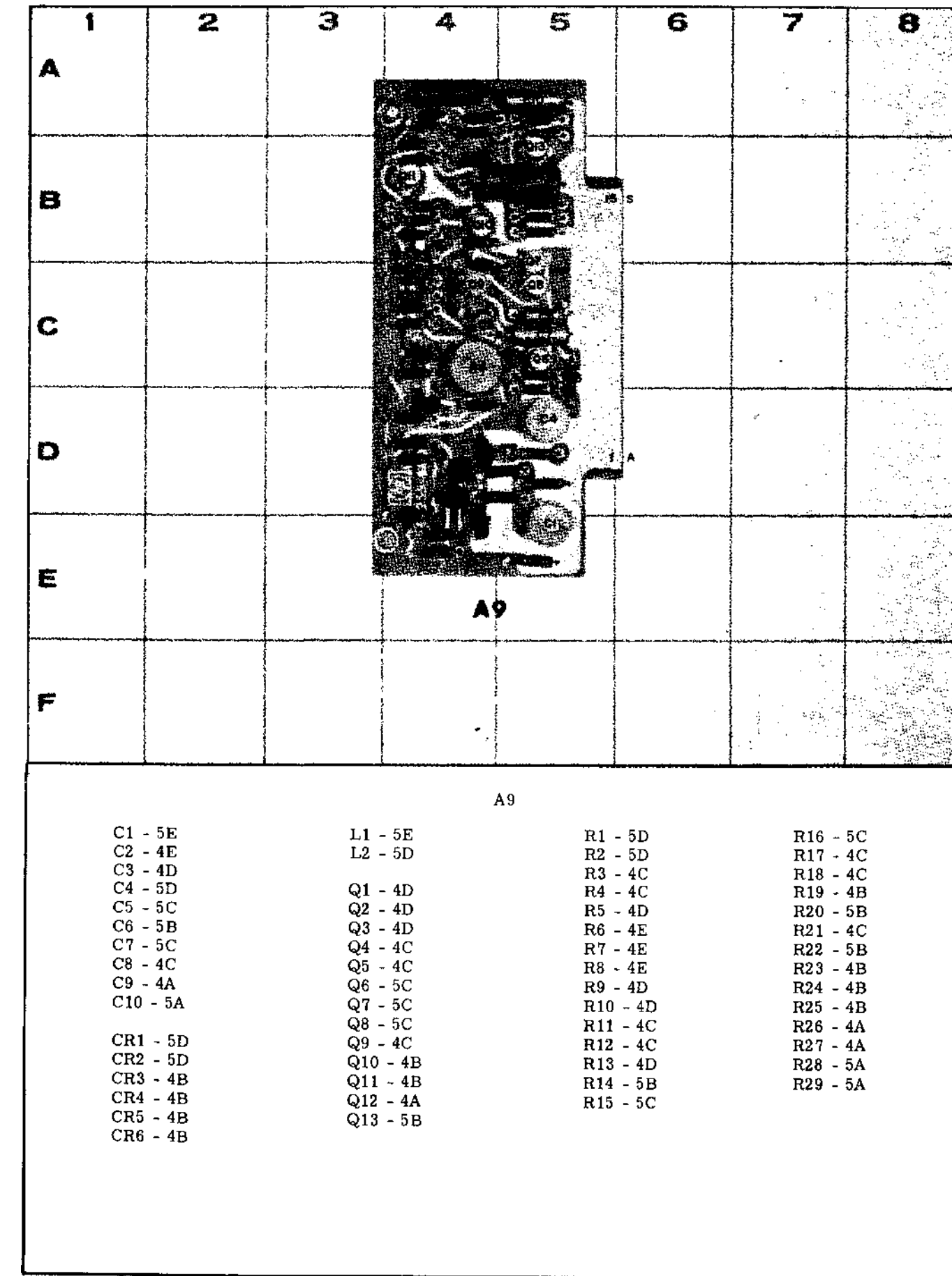

Figure 6-6. Prescaler Assembly A8
6-13/6-14



REFERENCE DESIGNATIONS WITHIN THIS ASSEMBLY ARE ABBREVIATED. ADD ASSEMBLY DESIGNATION AS PREFIX TO FORM COMPLETE DESIGNATION.

- NOTES**
- UNLESS OTHERWISE INDICATED RESISTANCE IN OHMS CAPACITANCE IN PICOFARADS INDUCTANCE IN MICROHENRIES
 - C10 AND C1 ARE FEED THROUGH FILTER NETWORKS

REFERENCE DESIGNATIONS

NO PREFIX	A9
C10 11	C1 - 10 CR1 - 6 L1 2
MI	Q1 - 13 R1 - 29

Figure 6-7. Control Circuit Assembly A9
6-15/6-16

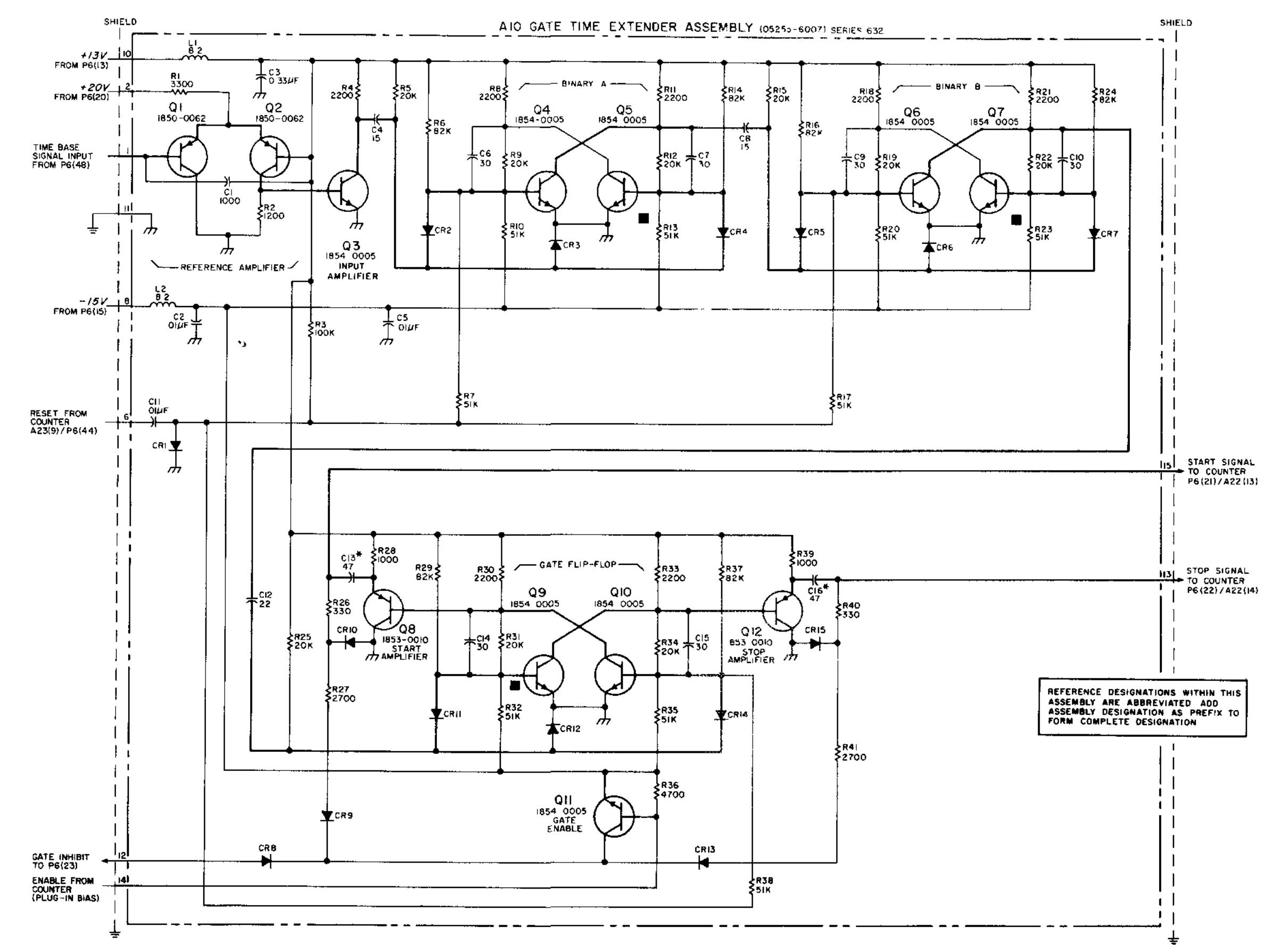
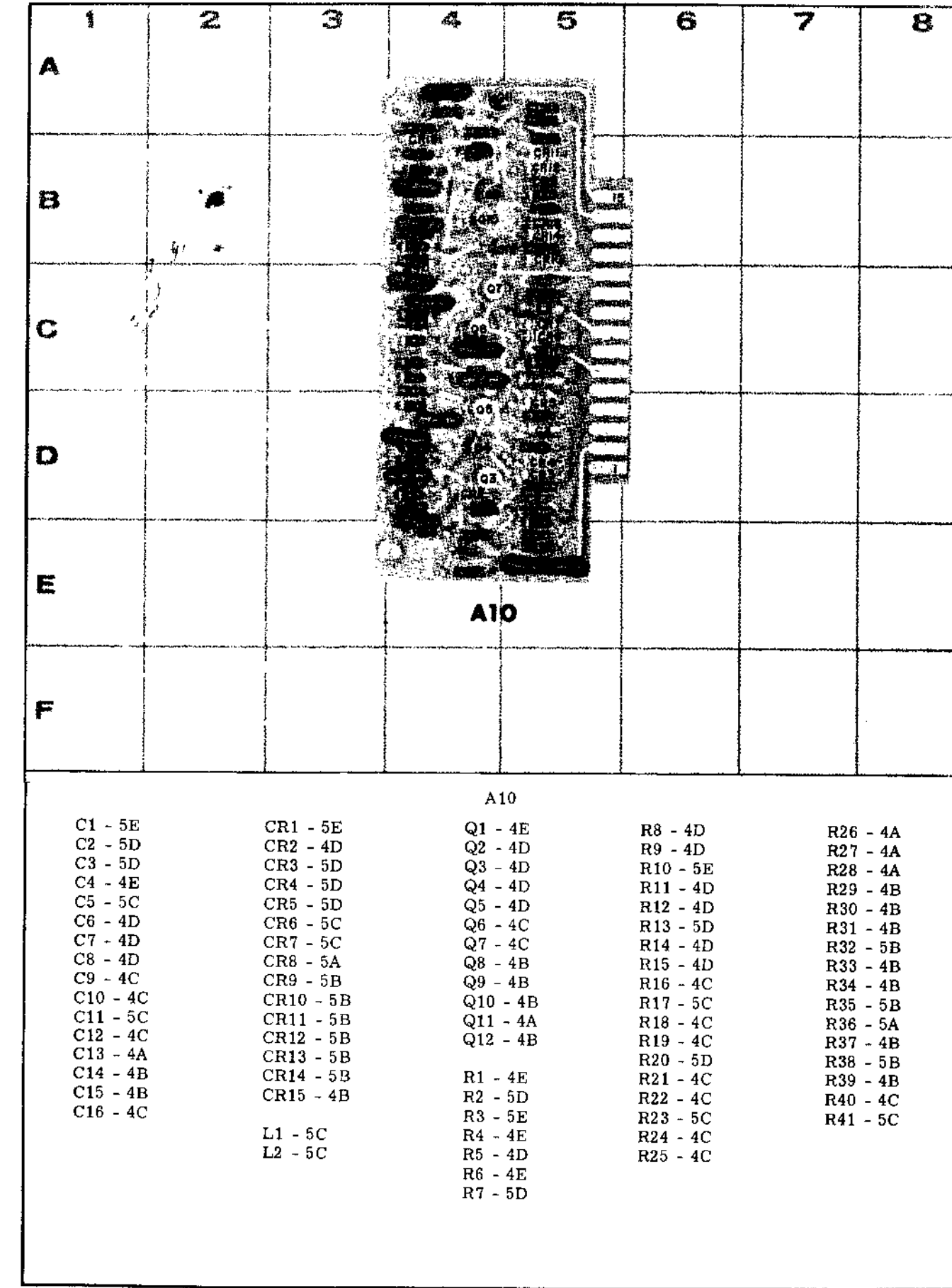

- NOTES**
- UNLESS OTHERWISE INDICATED RESISTANCE IN OHMS CAPACITANCE IN PICOFARADS INDUCTANCE IN MICROHENRIES
 - SQUARE (■) INDICATES CONDUCTING TRANSISTOR AFTER RESET
 - ASTERISK (*) INDICATES SELECTED COMPONENT AVERAGE VALUES SHOWN

REFERENCE DESIGNATIONS

A10	
C1 - 16	
CR1 - 15	
L1 - 2	
Q1 - 12	
R1 - 41	

REFERENCE DESIGNATIONS WITHIN THIS ASSEMBLY ARE ABBREVIATED ADD ASSEMBLY DESIGNATION AS PREFIX TO FORM COMPLETE DESIGNATION

Figure 6-8. Gate Time Extender Assembly A10
6-17/6-18

APPENDIX A

REFERENCES

The following publications contain information applicable to the operation and maintenance of the Frequency Converter.

		SB 38-100	Preservation, Packaging, and Packing Materials, Supplies, and Equipment Used by the Army.
DA PAM310-4	Index of Technical Manuals, Bulletins, Supply Manuals (types 7, 8, and 9), Supply Bulletins, and Lubrication Orders.	TB SIG 222	Solder and Soldering.
		TB 746-10	Field Instructions for Painting and Preserving Electronics Command Equipment.
		TM 38-750	Army Equipment Record Procedures
DA PAM 310-7	U.S. Army Equipment Index of Modification Work Orders.	TM 740-90-1	Administrative storage of Equipment.

APPENDIX B

MAINTENANCE ALLOCATION

Section I. INTRODUCTION

B-1. General

This appendix provides a summary of the maintenance operations covered in the equipment literature. It authorizes categories of maintenance for specific maintenance functions on repairable items and components and the tools and equipment required to perform each function. This appendix may be used as an aid in planning maintenance operations.

B-2. Maintenance Functions

Maintenance functions will be limited to and defined as follows:

a. Inspect. To determine serviceability of an item by comparing its physical, mechanical, and electrical characteristics with established standards.

b. Test. To verify serviceability and to detect incipient electrical or mechanical failure by use of special equipment such as gages, meters, etc. This is accomplished with external test equipment and does not include operation of the equipment and operator type tests using internal meters or indicating devices.

c. Service. To clean, to preserve, to charge, and to add fuel, lubricants, cooling agents, and air. If it is desired that elements, such as painting and lubricating, be defined separately, they may be so listed.

d. Adjust. To rectify to the extent necessary to bring into proper operating range.

e. Align. To adjust two or more components or assemblies of an electrical or mechanical system so that their functions are properly synchronized. This does not include setting the frequency control knob of radio receivers or transmitters to the desired frequency.

f. Calibrate. To determine the corrections to be made in the readings of instruments or test equip-

ment used in precise measurement. Consists of the comparison of two instruments, one of which is a certified standard of known accuracy, to detect and adjust any discrepancy in the accuracy of the instrument being compared with the certified standard.

g. Install. To set up for use in an operational environment such as an encampment, site, or vehicle.

h. Replace. To replace unserviceable items with serviceable like items.

i. Repair. To restore an item to serviceable condition through correction of a specific failure or unserviceable condition. This function includes, but is not limited to welding, grinding, riveting, straightening, and replacement of parts other than the trial and error replacement of running spare type items such as fuses, lamps, or electron tubes.

j. Overhaul. Normally, the highest degree of maintenance performed by the Army in order to minimize time work in process is consistent with quality and economy of operation. It consists of that maintenance necessary to restore an item to completely serviceable condition as prescribed by maintenance standards in technical publications for each item of equipment. Overhaul normally does not return an item to like new, zero mileage, or zero hour condition.

k. Rebuild. The highest degree of materiel maintenance. It consists of restoring equipment as nearly as possible to new condition in accordance with original manufacturing standards. Rebuild is performed only when required by operational considerations or other paramount factors and then only at the depot maintenance category. Rebuild reduces to zero the hours or miles the equipment, or component thereof, has been in use.

l. Symbols. The uppercase letter placed in the appropriate column indicates the lowest level at

which that particular maintenance function is to be performed.

B-3. Explanation of Format

a. Column 1, Group Number. Column 1 lists group numbers, the purpose of which is to identify components, assemblies, subassemblies, and modules with the next higher assembly.

b. Column 2, Functional Group. Column 2 lists the noun names of components, assemblies, subassemblies and modules on which maintenance is authorized.

c. Column 3, Maintenance Functions. Column 3 lists the maintenance category at which performance of the specific maintenance function is authorized. Authorization to perform a function at any category also includes authorization to perform that function at higher categories. The codes used represent the various maintenance categories as follows:

Code	Maintenance Category
C	Operator/crew
O	Organizational maintenance
F	Direct support maintenance
H	General support maintenance
D	Depot maintenance

d. Column 4, Tools and Test Equipment. Column

4 specifies, by code, those tools and test equipment required to perform the designated function. The numbers appearing in this column refer to specific tools and test equipment which are identified in table I.

e. Column 5, Remarks. Self-explanatory.

B-4. Explanation of Format of Table I, Tool and Test Equipment Requirements

The column in table I, Tool and Test Equipment Requirements, are as follows:

a. Tools and Equipment. The numbers in this column coincide with the numbers used in the tools and equipment column of the applicable tool for the maintenance function.

b. Maintenance Category. The codes in this column indicate the maintenance category normally allocated the facility.

c. Nomenclature. This column lists tools, test, and maintenance equipment required to perform the maintenance functions.

d. Federal Stock Number. This column lists the Federal stock number of the specific tool or test equipment.

e. Tool Number. Not used.

SECTION II. MAINTENANCE ALLOCATION CHART

GROUP NUMBER	FUNCTIONAL GROUP	MAINTENANCE FUNCTIONS										TOOLS AND EQUIPMENT	REMARKS	
		INSPECT	TEST	SERVICE	ADJUST	ALIGN	CALIBRATE	INSTALL	REPLACE	REPAIR	OVERHAUL			REBUILD
1	FREQUENCY CONVERTER MODEL 5255A	H	H		H				H	H			1,14 thru 23 1,14 thru 23	Visual Defective modules. Replace hard-wired defective piece parts.
1A	BOARD ASSY, 200 MHz Amplifier 6001	H	H		H				H	H			1,19,20,22 1,19,20,22 1,19,20,22 1	Visual Repair by replacement
1B	BOARD ASSY, 50 MHz AMPLIFIER 6002	H	H		H				H	H			1,16,19,20, 22 1,16,19,20, 22 1,16,19,20, 22 1	Visual Repair by replacement
1C	VIDEO AMPLIFIER ASSY 6028	H							H	H			1,18 1 thru 23	Visual
1D	CAVITY ASSEMBLY, MIXER 6013	H							H	H			1,18 1 thru 23	Visual
1E	BOARD ASSEMBLY, OSCILLATOR 6003	H	H		H					H			1,18,19,20, 22 1,18,19,20, 22 1	Visual Repair by replacement

MAINTENANCE ALLOCATION CHART

GROUP NUMBER	FUNCTIONAL GROUP	MAINTENANCE FUNCTIONS											TOOLS AND EQUIPMENT	REMARKS	
		INSPECT	TEST	SERVICE	ADJUST	ALIGN	CALIBRATE	INSTALL	REPLACE	REPAIR	OVERHAUL	REBUILD			
1F	CONTROL BOARD ASSEMBLY 6005	H	H		H					H				16,17,22,23 16,17,22,23 16,17,22,23 16,17,22,23	Visual
1G	PRESALER BOARD ASSEMBLY 6006	H	H							H				1,2,3,18 1,2,3,18 1,2,3,18	Visual
1H	GATE TIME EXTENDER BOARD ASSEMBLY 6007	H	H											1	Visual Operational test only. Repair by replacement
1I	HARMONIC GENERATOR ASSEMBLY 6016	H	H		H					H				1,14,15,16 1,14,15,16 1,14,15,16 1 thru 23	Visual
1J	PHASE DETECTOR BOARD ASSEMBLY 6004	H			H					H				1,16,18,22 1,16,18,22 1 thru 23	Visual

TABLE I. TOOL AND TEST EQUIPMENT REQUIREMENTS

TOOLS AND EQUIPMENT	MAINTENANCE CATEGORY	NOMENCLATURE	FEDERAL STOCK NUMBER	TOOL NUMBER
1	H	ELECTRONIC COUNTER, HEWLETT-PACKARD 5245L		
2	H	SWEEP OSCILLATOR, HEWLETT-PACKARD 8690		
3	H	TEST OSCILLATOR, HEWLETT-PACKARD 651B		
4	H	VHF OSCILLATOR, HEWLETT-PACKARD 3200B		
5	H	QUARTZ OSCILLATOR, HEWLETT-PACKARD 107BR		
6	H	POWER METER, HEWLETT-PACKARD 431C		
7	H	THERMISTOR MOUNT, HEWLETT-PACKARD 486A		
8	H	FREQUENCY SYNTHESIZER, HEWLETT-PACKARD 2654A		
9	H	SIGNAL GENERATOR, HEWLETT-PACKARD 626A		
10	H	WAVEGUIDE DIRECTIONAL COUPLER, HEWLETT-PACKARD 752C		
11	H	WAVEGUIDE TO COAX ADAPTERS, HEWLETT-PACKARD 281A		
12	H	COAX ATTENUATOR, HEWLETT-PACKARD 355D		
13	H	COAX ATTENUATOR, HEWLETT-PACKARD 355C		
14	H	COAX DIRECTIONAL COUPLER, HEWLETT-PACKARD 774D		
15	H	CRYSTAL DETECTOR, HEWLETT-PACKARD 423A		
16	H	OSCILLOSCOPE, HEWLETT-PACKARD 175A WITH 1750B and 1780A PLUG-IN'S		
17	H	POWER SUPPLY, HEWLETT-PACKARD 6205B		
18	H	D.C. VOLTMETER, HEWLETT-PACKARD 412A		
19	H	RF MILLIVOLTMETER, HEWLETT-PACKARD 411A		
20	H	50 OHM COAX TERMINATION, HEWLETT-PACKARD 908A		
21	H	EXTENDER CABLE, HEWLETT-PACKARD 10506B		
22	H	EXTENDER BOARDS (4 EACH) HEWLETT-PACKARD 05245-6022		
23	H	SWEEP GENERATOR, JERROLD 900B		

By Order of the Secretary of the Army:

W. C. WESTMORELAND,
*General, United States Army,
Chief of Staff.*

Official:

VERNE L. BOWERS,
*Major General, United States Army,
The Adjutant General.*

Distribution:

Active Army:

CNGB (1)
USASA (2)
ACSC-E (2)
USAMB (10)
AMC (1)
USACDCCEA Ft Huachuca (1)
2d LOGCOMD (10)
ARADCOM (1)
OS Maj Cored (8)
USARPAC (8)
USARYIS (8)
TECOM (2)
USASTRATCOM (6)
USASTRATCOM SIG GP Okinawa (16)
USASTRATCOM SIG GP-T (2)
USASTRATCOM SIG GP Taiwan (10)
USASTRATCOM-PAC (10)
USASTRATCOM Comm Op Bn, Korea (2)
USARV (10)
Eighth USA (10)
1st Sig Bde (6)
USAINTS (3)
USASCS (60)
USASESS (5)

NG: None

USAR : None

USAESC (20)
Depots (1) except
SAAD (20)
TOAD (14)
LBAD (6)
LEAD (6)
USA Dep (Pac) (2) except
Ascom (3)
Cp Carroll (3)
Cam Rahn Bay (3)
Long Binh (3)
Qui Nhon (3)
Sig Sec USA Dep (Pac) (2)
Sig Dep (Pac) (2)
Sig FLDMS (Pac) (2)
MAAG, Republic of China (2)
Taiwan Defense Cored (5)
USACSA (3)
Unite org under fol TOE:
(1 copy each)
11-158
11-302
29-184
29-136

**DEPARTMENT OF THE ARMY
US ARMY AG PUBLICATIONS CENTER
1655 WOODSON ROAD
ST. LOUIS, MISSOURI 63114**

**OFFICIAL BUSINESS
PENALTY FOR PRIVATE USE, \$300**

**POSTAGE AND FEES PAID
DEPARTMENT OF THE ARMY
DOD 314
FOURTH CLASS**

